

SYSTEMS DATA

SECTION 2

SUBSECTION 2.8

TELECOMMUNICATION SYSTEM
(CSM 106 & SUBS)

2.8.1 INTRODUCTION.

The communications subsystem is the only link between the spacecraft and the manned space flight network (MSFN). In this capacity, the communications subsystem provides the MSFN flight controllers with data through the pulse code modulated (PCM) telemetry system for monitoring spacecraft parameters, subsystem status, crew biomedical data, event occurrence, and scientific data. As a voice link, the communications subsystem gives the crew the added capability of comparing and evaluating data with MSFN computations. The communications subsystem, through its MSFN link, serves as a primary means for the determination of spacecraft position in space and rate of change in position. CM-LM rendezvous is facilitated by a ranging transponder and active ranging system. Through the use of the television camera, crew observations and public information can be transmitted in real time to MSFN. A means by which CM and LM telemetry and voice can be stored in the spacecraft for later playback, to avoid loss because of an interrupted communications link, is provided by the communications subsystem in the form of the data storage equipment (DSE). Direction finding aids are provided for postlanding location and rescue by ground personnel.

The following list summarizes the general telecomm functions:

Provide voice communication between

- Astronauts via the intercom
- CSM and MSFN via the unified S-band equipment (USBE) and in orbital and recovery phases via the VHF/AM
- CSM and extravehicular astronaut (EVA) via VHF/AM
- CSM and LM via VHF/AM
- CSM and launch control center (LCC) via PAD COMM
- CSM and recovery force swimmers via swimmers umbilical
- Astronauts and the voice log via intercomm to the data storage equipment

TELECOMMUNICATION SYSTEM

SYSTEMS DATA

Provide data to the MSFN of

- CSM system status
- Astronaut biomedical status
- Astronaut activity via television
- EVA personal life support system (PLSS) and biomed status
- LM system status recorded on CSM data storage equipment

Provide update reception and processing of

- Digital information for the command module computer (CMC)
- Digital time-referencing data for the control timing equipment (CTE)
- Real time commands to remotely perform switching functions in three CM systems

Facilitate ranging between

- MSFN and CSM via the USBE transponder
- LM and CSM via the rendezvous radar transponder (RRT)
- CSM and LM via the VHF/AM ranging system

Provide recovery aid

- VHF beacon for location

Provide a time reference for all time-dependent spacecraft subsystems except the guidance and navigation subsystem.

2.8.2 FUNCTIONAL DESCRIPTION.

The functional description of the T/C system is divided into four parts: intercommunications equipment, data equipment, radio frequency equipment, and antenna equipment. All of these functional groups of equipment interface with each other to perform the system tasks. In the functional descriptions of these parts, such interfaces will be apparent. The equipment that falls into each group is shown in figure 2.8-1.

SYSTEMS DATA

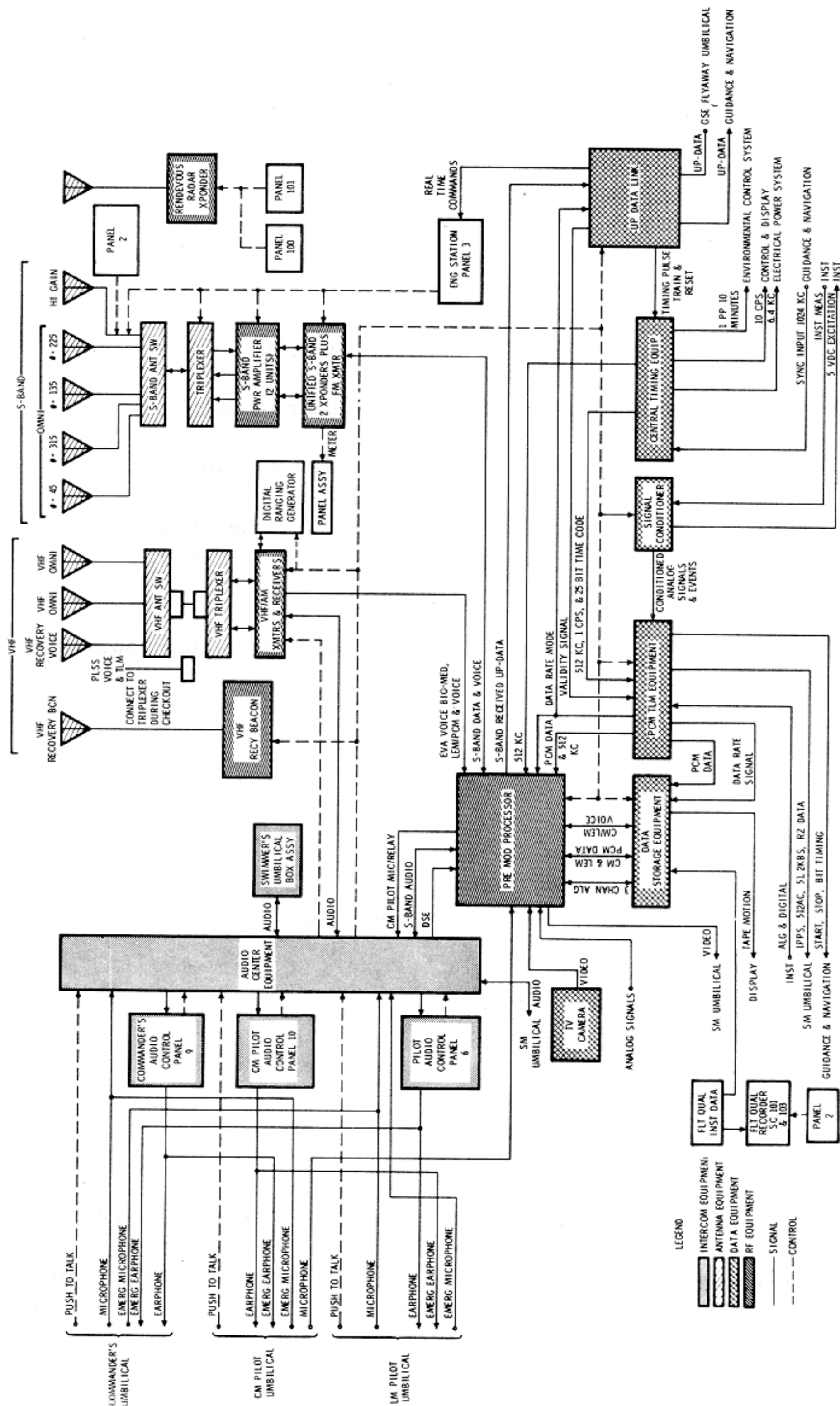

CO-2000

Figure 2.8-1. Telecommunications System

T/C

TELECOMMUNICATION SYSTEM

SYSTEMS DATA

2.8.2.1 Intercommunications Equipment.

2.8.2.1.1 General.

The functions performed by the intercommunications equipment can be summarized as providing the means for each astronaut to interface or isolate himself to or from the

- Intercomm for astronaut-to-astronaut communications
- Pad communications for astronaut-to-launch control center communications
- VHF/AM for astronaut-to-MSFN, EVA, or LM communications
- USBE for astronaut-to-MSFN communications
- Data storage equipment for a voice log (via intercomm)
- Swimmers umbilical during recovery (via intercomm).

2.8.2.1.2 Equipment.

The equipment that falls into the intercommunications grouping is listed as follows:

- Personal communications assembly
- T-adapter cable
- Communications cable
- Audio control panels (MDC-6, -9, -10)
- Audio center
- Swimmers umbilical cable.

2.8.2.2 Data Equipment.

2.8.2.2.1 General.

The functions of the data equipment can be summarized as providing

- Information gathering and encoding (telemetry) of critical spacecraft and astronaut parameters

SYSTEMS DATA

- Conditioning of instrumentation inputs for compatibility with the telemetry equipment
- Storage and playback capabilities of CSM and LM telemetering data, voice log, and scientific parameters
- Decoding and distributing of up-data to the proper switching or information receiving systems
- Frequency and/or time code signals to other spacecraft equipment

2.8.2.2.2 Equipment.

The equipment that falls under the data grouping is as follows:

- Central timing equipment (CTE)
- Signal conditioning equipment (SCE)
- Pulse code modulation (PCM) telemetering equipment
- Television (TV) camera
- Data Storage Equipment
- Up-data link (UDL) equipment.

2.8.2.3 Radio Frequency Equipment.

2.8.2.3.1 General.

The functions performed by the RF equipment can be summarized as the transmission and reception of

- Voice information between
 - CM and MSFN
 - CM and LM
 - CM and EVA
 - CM and recovery forces
- Telemetering data
 - Between CM and MSFN
 - From LM to CM to MSFN
 - From EVA to CM to MSFN
- Television from CM to MSFN

T/C

SYSTEMS DATA

- Ranging and beacon (BCN) information

Pseudo-random noise ranging signals from MSFN to CM to MSFN

Double doppler ranging signals from MSFN to CM to MSFN

X-band radar signals from LM to CM to LM

VHF ranging signals from CM to LM to CM

VHF beacon signals from CM to recovery forces.

2.8.2.3.2 Equipment.

As shown in figure 2.8-1, the equipment that falls into the radio frequency grouping is

- VHF/AM transceivers A & B
- Digital ranging generator
- Unified S-band equipment (primary and secondary xponders and FM xmitter)
- S-band power amplifiers (primary and secondary)
- VHF beacon
- X-band xponder (rendezvous radar)
- Premodulation processor.

2.8.2.4 Antenna Equipment.

The antenna equipment can be divided into three groups: VHF antennas and ancillary equipment, S-band antennas and ancillary equipment, and beacon antenna. Their overall function is to propagate and receive RF signals from and to the RF equipment. The ancillary equipment includes two RF switches, 2 triplexers, and the servo-drive system for the high-gain antenna (figure 2.8-2).

2.8.3 MAJOR COMPONENT/SUBSYSTEM DESCRIPTION.

To facilitate this presentation, the functional divisions established in the previous section will be retained. In many instances, however, when an operational mode is being explained, interfacing equipment of another division will be discussed to present a complete picture.

SYSTEMS DATA

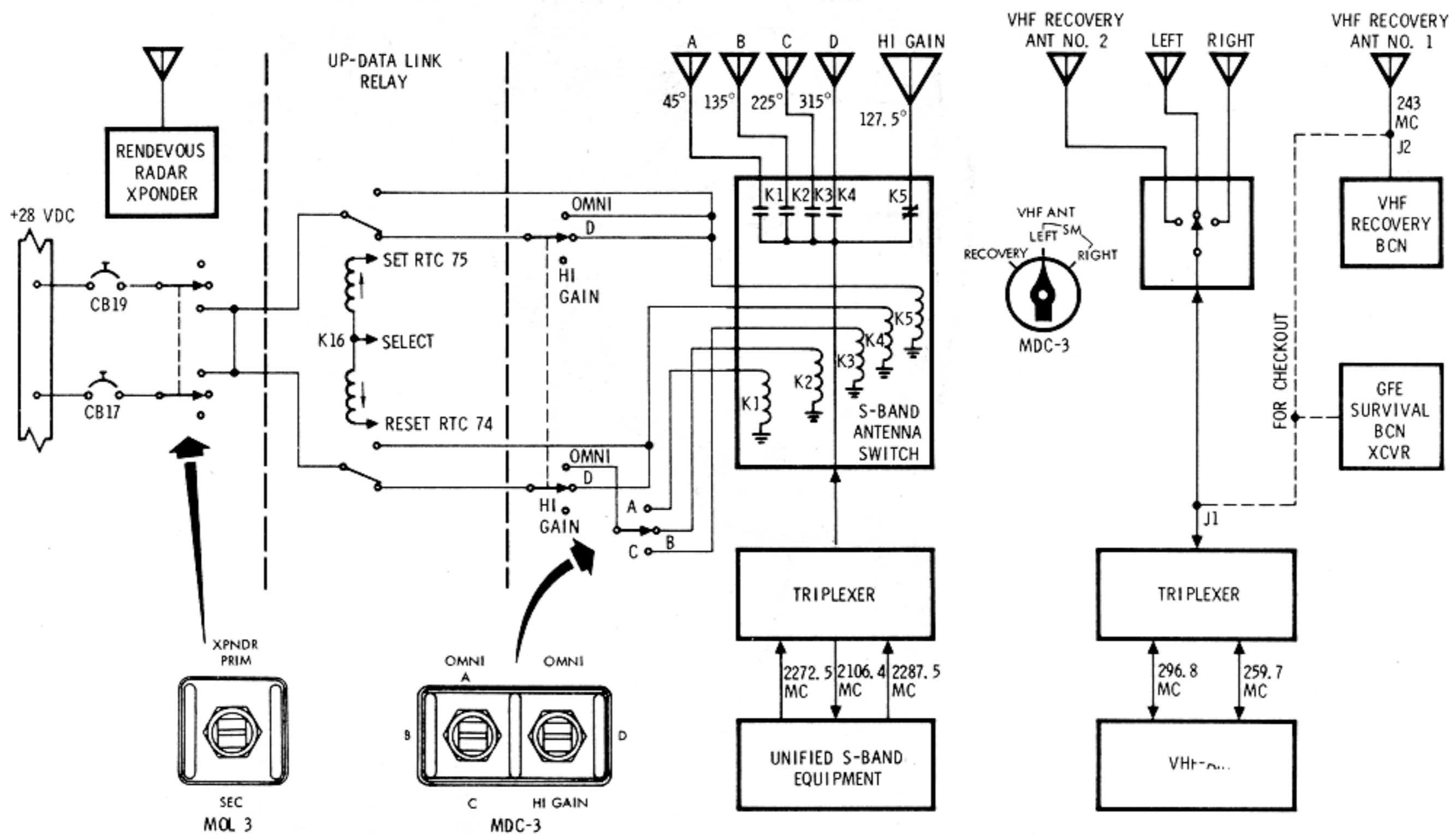

Figure 2.8-2. Antenna Equipment Switching

2.8.3.1 Intercommunication Equipment.

2.8.3.1.1 Personal Communications Assembly (Comm Carrier).

As shown in figure 2.8-3 the personal communications assembly (comm carrier) contains redundant earphones and microphones. The comm carrier can be worn with the space suit, flight coveralls, or constant wear garment. When used with the space suit, the comm carrier is interfaced with an integral wiring harness in the suit. A T-adaptor cable is required when the comm carrier is worn with the flight coveralls or just the constant wear garment to interface to headset with the comm cable.



SYSTEMS DATA



CD-1018B

Figure 2.8-3. Personal Communications Assembly

Three lightweight headsets are also available for use in the CM. They have a single earphone and microphone with a lightweight head clamp and connecting cable.

2.8.3.1.2 T-Adapter Cable (Figure 2.8-4).

The T-adapter cable is used when the astronaut is wearing his flight coveralls or just his constant wear garment to connect the personal communications assembly and biomed preamplifiers to the comm cable. An integral cable assembly performs this function when the astronaut is in his space suit so no T-adapter is necessary. Besides handling the audio signals to and from the comm carrier, the T-adapter must handle 16.8 volts needed by the microphone preamps and biomed preamps. The output of the biomed preamps is also routed to the comm cable.

SYSTEMS DATA

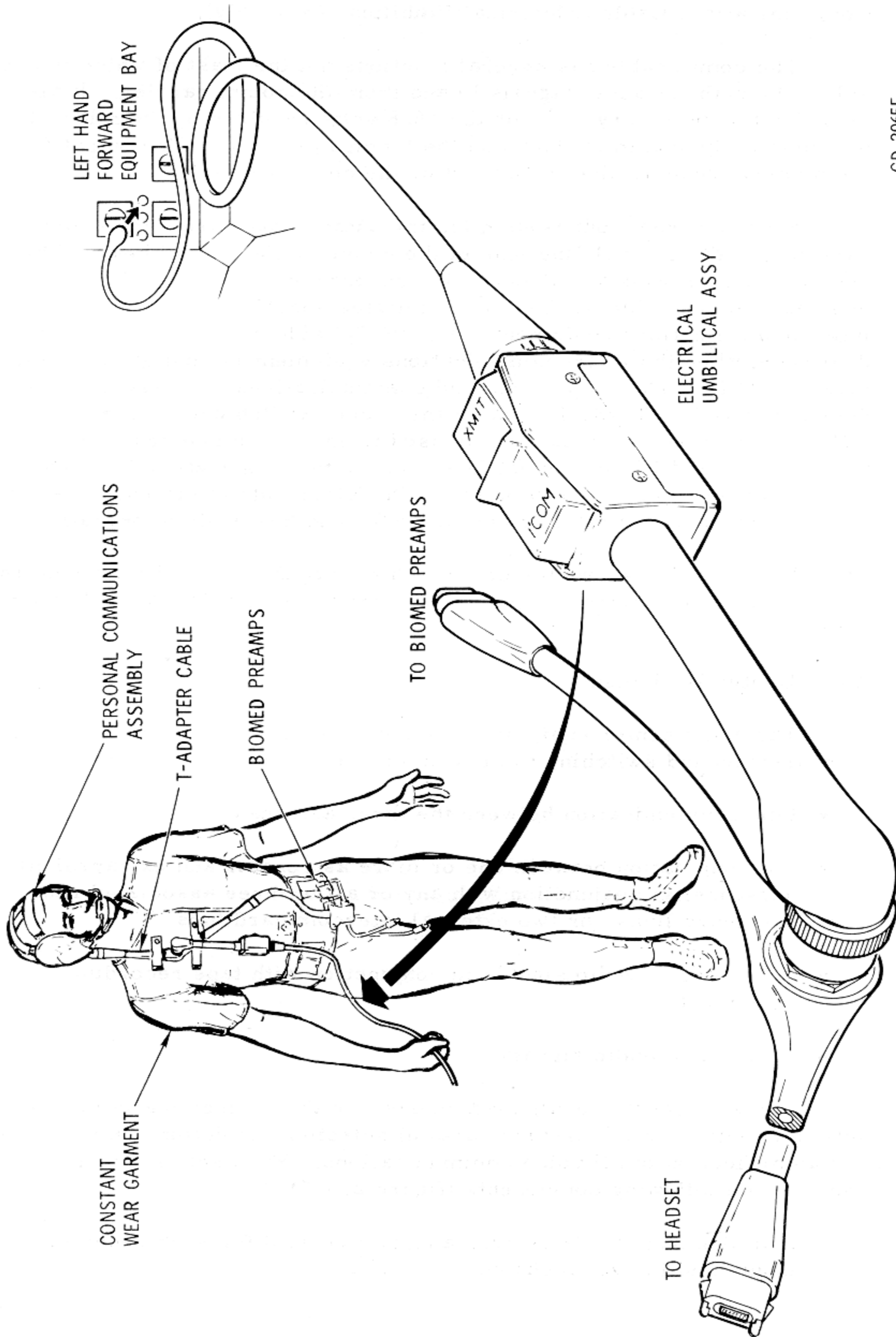

CD-2065E

Figure 2.8-4. Communications Cable

T/C

TELECOMMUNICATION SYSTEM

SYSTEMS DATA

2.8.3.1.3 Communications Cable (Electrical Umbilical Assembly).

The comm cable has several functions not the least of which is providing the path for audio signals to and from the comm carrier. It also provides the necessary path for the 16.8 volts required by the microphone preamps in the comm carrier and the biomed preamps. The output from the biomed preamps also is carried by the comm cable.

Separate from, but related to, the audio signals from the comm carrier are the control functions of the comm cable control head. This control head contains a self-centering rocker switch which, when depressed on one side or the other, initiates specific functions in the intercommunications equipment. The I'COM side of the rocker switch is depressed when the intercommunications equipment is configured in the manual (PTT) mode of operation and communications over just the intercom is desired. The XMIT side of the rocker switch can be used for two different functions. Normally it is used to enable communications over the intercom and RF equipment in any of the three operational modes of the intercommunications equipment. The XMIT side of the rocker switch can also be used as a sending key in the S-band key mode of operation.

Figure 2.8-4 shows the comm cables interface with the connectors on the left-hand forward equipment bay (below panel 301) and the T-adaptor cable.

2.8.3.1.4 Audio Center Equipment.

The audio center equipment accomplishes the necessary audio signal amplification and switching to provide the capability of the following:

- Intercommunication between the three astronauts
- Communication between one or more astronauts and extravehicular personnel in conjunction with any or all of three associated radio frequency links, or two external intercom hardlines
- Recording of audio signals in conjunction with tape recording equipment
- Relaying of audio signals.

The audio center equipment consists of three electrically identical sets of circuitry which provide parallel selection, isolation, gain control, and amplification of all voice communications. Each set of circuitry contains the following components (figure 2.8-5):

- Isolation pad, diode switch, and gain control for each receiver input, and intercom channel.

SYSTEMS DATA

- Isolation pad and diode switch for each transmitter modulation output and intercom channel.
- An earphone amplifier and a microphone amplifier.
- Voice-operated relay (VOX) circuitry with externally controlled sensitivity.

The equipment operates with three remote control panels to form three audio stations, each providing an astronaut with independent control of all common functions. Each station has the capability of accommodating a second astronaut for emergency operation. Provision is made in each station to enable voice transmission over any or all transmitters by means of a voice-operated relay (VOX) circuit or push-to-talk (PTT) circuit. A "hot mike" is so incorporated as to maintain continuous intercrew communication using the INTERCOM/PTT mode, and to require PTT operation for external transmission. Enabling a TRANSMIT function also enables the corresponding RECEIVE function. Sidetone is provided in all transmit modes.

Audio signals are provided to and from the VHF/AM transmitter-receiver equipment. USBE (via the PMP), the PAD COMM, and intercom bus. The PAD COMM, intercom bus, and all transmitter-receiver equipments are common to all three stations.

Inputs and outputs are controlled by the VHF/AM, S-BAND, PAD COMM, and INTERCOM switches on the audio control panels. Each of these switches has three positions: T/R, OFF, and RCV. Setting any of the switches to T/R permits transmission and reception of voice signals over its respective equipment, RCV permits reception only, and OFF disables the input and the output. The POWER switch of each station, in either AUDIO/TONE or AUDIO, energizes the earphone amplifier to permit monitoring. The AUDIO/TONE position also enables the audible crew alarm to be heard, if triggered, at the respective SC station. Each SC station can be isolated from the alarm by selecting the AUDIO or OFF position. The operation of the microphone amplifier in each station is controlled by the VOX keying circuit or the PTT pushbutton on the comm cable or on the rotation controller. The VOX circuit is energized by the VOX position of the MODE switch on each audio control panel. When energized, the VOX circuit will enable both the intercom and accessed transmitter keying circuits. The INTERCOM/PTT position permits activation of the PAD COMM, VHF/AM, and S-band voice transmission circuits by the PTT key while the intercom is on continuously. The PTT position permits manual activation of the intercom or intercom and transmitter keying circuits by depression of the I'COM or XMIT side of the communication cable switch, respectively.

T/C

TELECOMMUNICATION SYSTEM

SYSTEMS DATA

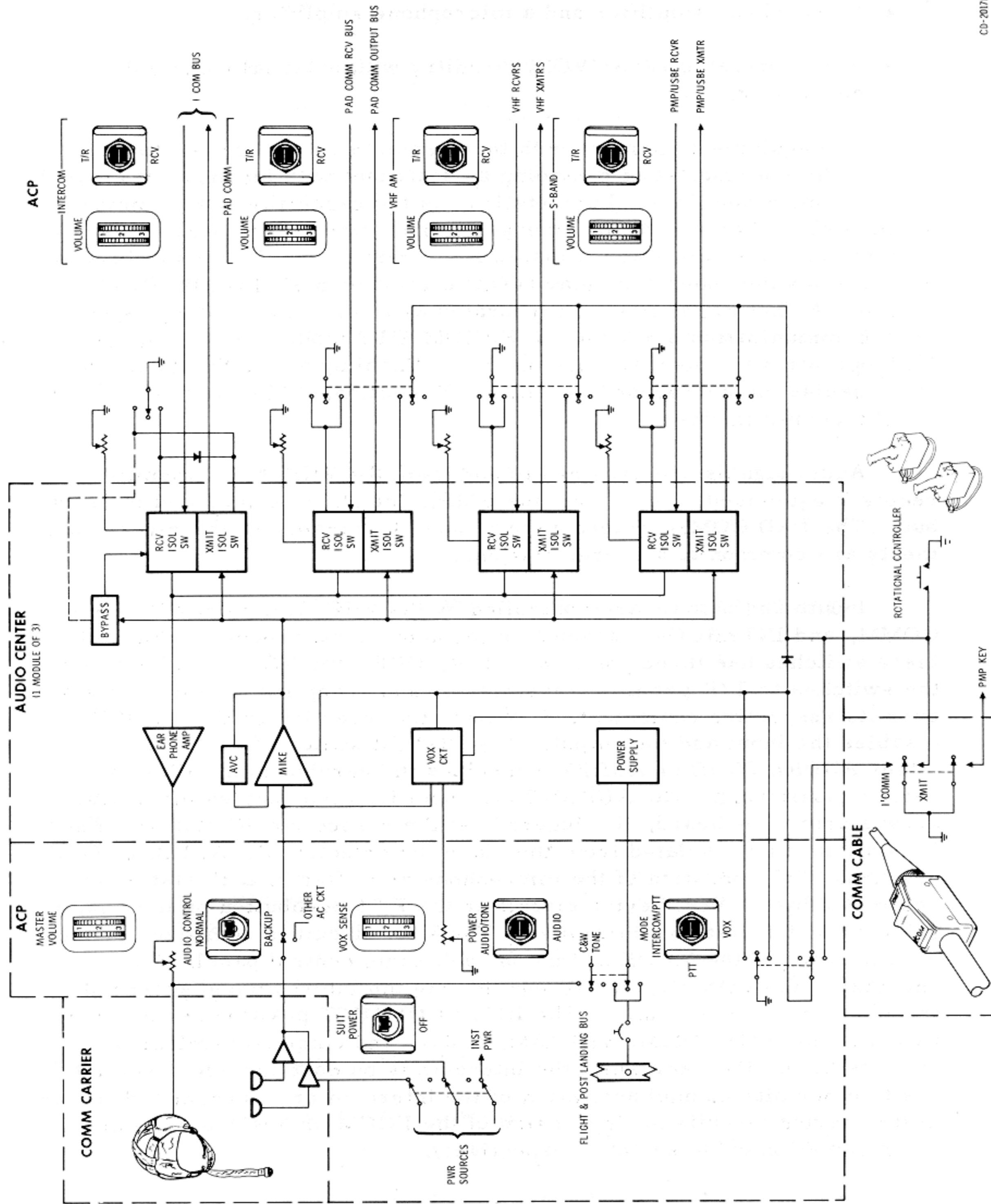

CO-2017K

Figure 2.8-5. Audio Center

TELECOMMUNICATION SYSTEM

SYSTEMS DATA

Six potentiometer controls are provided on each audio control panel: VOX SENS, PAD COMM, S-BAND, INTERCOM, VHF/AM and MASTER VOLUME. The VOX SENS control is used to adjust the sensitivity of the VOX circuitry, determining the amplitude of the voice signal necessary to trigger the VOX keying circuit. The PAD COMM, S-BAND, VHF/AM, and INTERCOM volume controls are used to control the signal levels from the respective units to the input of the earphone amplifier. The MASTER VOLUME controls the level of the amplified signal going to the earphones.

The intercom bus connects to the recovery interphone (swimmer umbilical), and the premodulation processor which in turn routes the signal to the data storage equipment for recording.

An AUDIO SELECT switch on each audio control panel allows the astronaut to access himself to the normal audio center circuits for that station, or through a selection of the BACKUP position, access himself to the audio control panel and audio center of another station. In the BACKUP position the commander is accessed to the LM pilot's panel and audio center, while BACKUP for the CM pilot accesses him to the commander's panel and audio center. The LM pilot is accessed to the CM pilot's panel and audio center if he selects the BACKUP mode.

A SUIT POWER switch on each panel controls application of power to the respective astronauts personal communications assembly microphone preamplifiers and the biomed preamplifiers contained in his constant wear garment.

It is important to note that most signal processing done by the audio center is of preparatory nature. In order for any audio signal to be transmitted or received, the RF equipment must be in the proper operational mode.

T/C

2.8.3.1.5 Swimmers Umbilical Cable.

The swimmers umbilical cable is deployed with the dye marker in the recovery phase of the mission. It provides a hard-line connection to the spacecraft intercom bus for the recovery force swimmers. Actual deployment is accomplished by activating the guarded DYE MARKER switch on MDC-8 which provides 28 vdc to a pyrotechnic actuator.

2.8.3.2 Intercommunication System Interfaces.

Figure 2.8-6 illustrates the interfaces between the intercommunications group and the other telecommunications equipment. One interface shown that is not readily apparent is the signal path used in the relay mode of operation. This mode of operation ties the VHF AM and S-band equipment together to provide a three-way conference capability between the

SYSTEMS DATA

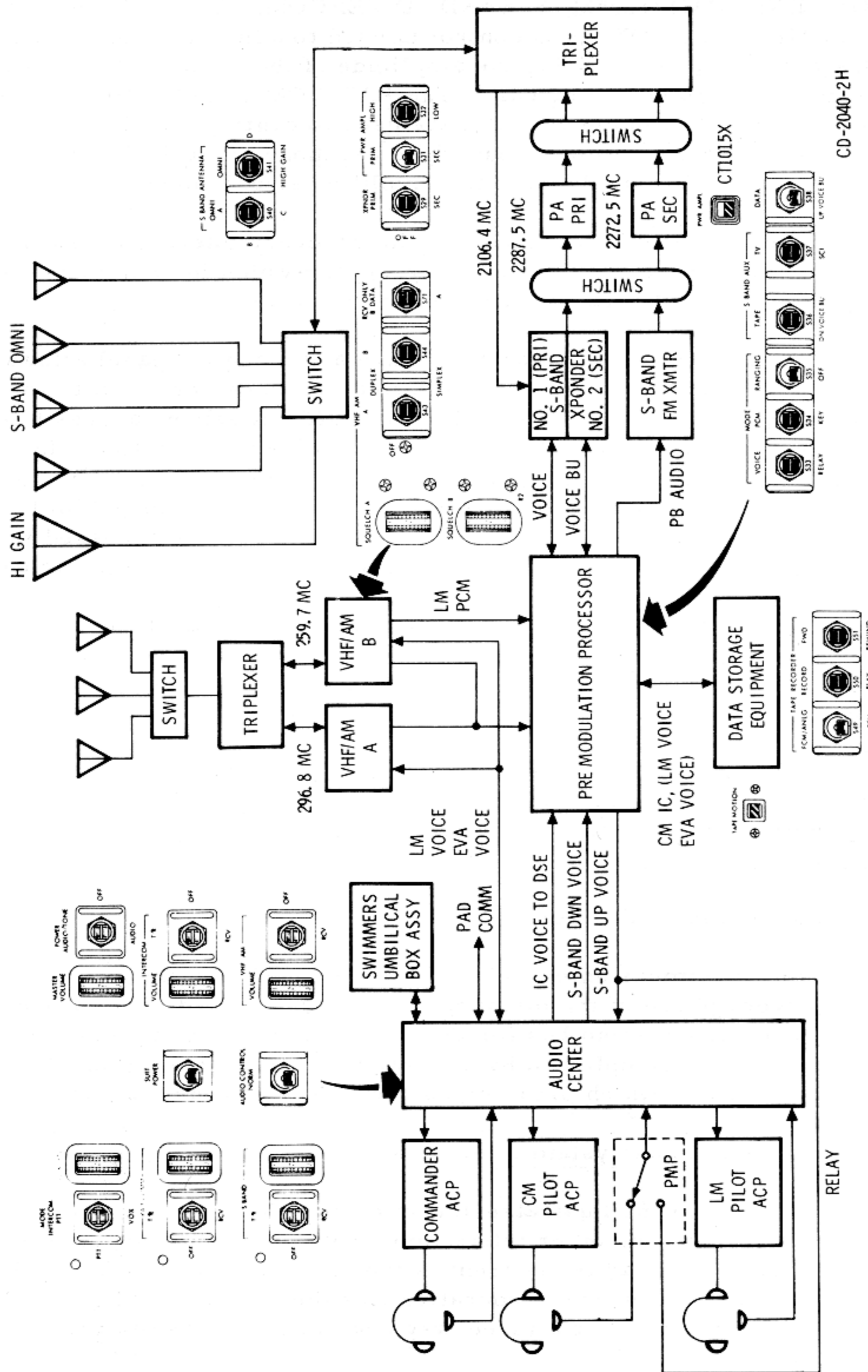

Figure 2.8-6. Audio Interfaces

SYSTEMS DATA

MSFN, CM and LM, or EVA. The intercommunications equipment enters this process when the received MSFN voice signal (S-band or voice) is routed to the microphone input of the CM pilot. Then, through proper switching, this signal is routed to the VHF AM transmitter for relaying to the LM or EVA. In the relay mode, the CM pilot's microphone is not usable. The return relay is accomplished by adding the VHF/AM received voice to the normal S-Band down voice channel.

Another function not too obvious is voice log recording and playback. The intercomm bus of the audio center is connected through the premodulation processor to the data storage equipment (DSE). Any time the DSE is recording, the conversation on the intercomm bus will be recorded as well, in some instances, as the received voice from the VHF/AM equipment. There are no provisions to monitor this recorded voice in the SC.

2.8.3.3 Data Equipment.

2.8.3.3.1 Instrumentation Equipment Group.

The SC instrumentation equipment consists of various types of sensors and transducers for providing environmental, operational status, and performance measurements of the SC structure, operational systems, and experimental equipment. The outputs from these sensors and transducers are conditioned into signals suitable for utilization by the SC displays, presentation to the PCM TLM equipment, or both. In addition, various digital signals are presented to the PCM TLM equipment, including event information, guidance and navigation data, and a time signal from the CTE.

Many of the signals emanating from the instrumentation sensors are of forms or levels which are unsuitable for use by the SC displays or PCM TLM equipment. Signal conditioners are used to convert these signals to forms and levels which can be utilized. Some signals are conditioned at or near the sensor by individual conditioners located throughout the SC. Other signals are fed to the signal conditioning equipment (SCE), a single electronic package located in the lower equipment bay. (Refer to paragraph 2.8.3.3.5 for signal conditioning equipment.) In addition to conditioning many of the signals, the SCE also supplies 5-volt d-c excitation power to some sensors. The SCE can be turned on or off with the POWER-SCE switch on MDC-3. This is the only control that the crew can exercise over instrumentation equipment for operational and flight qualification measurements. These two instrumentation groups are discussed in paragraphs 2.8.3.3.2 and 2.8.3.3.3

2.8.3.3.2 Operational and Flight Qualification Instrumentation.

Operational measurements are those which are normally required for a routine mission and include three categories: in-flight management

TELECOMMUNICATION SYSTEM

SYSTEMS DATA

of the SC, mission evaluation and system performance, and preflight checkout of the SC. The operational instrumentation sensors and transducers are capable of making the following types of measurements: pressure, temperature, flow, rate, quantity, angular position, current, voltage, frequency, RF power, and "on-off" type events.

Flight qualification measurements may vary between SC, depending on mission objectives and state of hardware development. These measurements will be pulse-code modulated along with the operational measurements and transmitted to the MSFN.

2.8.3.3.3 Data Equipment Interfaces.

Figure 2.8-7 illustrates the major interfaces between the units that make up the data equipment and their interfaces with the RF equipment group.

2.8.3.3.4 Central Timing Equipment (CTE).

The CTE provides precision square-wave timing pulses of several frequencies to time-correlate all SC time-sensitive functions. It also generates and stores the real-time day, hour, minute, and second mission elapse time (MET), in binary-coded decimal (BCD) format for transmission to the MSFN. (See figure 2.8-8.)

In the primary or normal mode of operation, the command module computer (CMC) provides a 1024-kc sync pulse to the CTE. This automatically synchronizes the CTE with the CMC and provides a stability of $\pm 2 \times 10^{-6}$ parts in 14 days. In the event of sync pulse failure, the CTE automatically switches to the secondary mode of operation with no time lapse and operates using its own crystal oscillator at a stability reduced to $\pm 2.2 \times 10^{-6}$ parts in 5 days.

The CTE requires approximately 20 watts of 28-vdc power for its two redundant power supplies. Each one is supplied from a different power source and through separate circuit breakers. These circuit breakers, CENTRAL TIMING SYS-MN A and - MN B on MDC-225, provide the only external means of control for the CTE. The two power supplies provide paralleled 6-volt d-c outputs, either one of which is sufficient to power the CTE.

SYSTEMS DATA

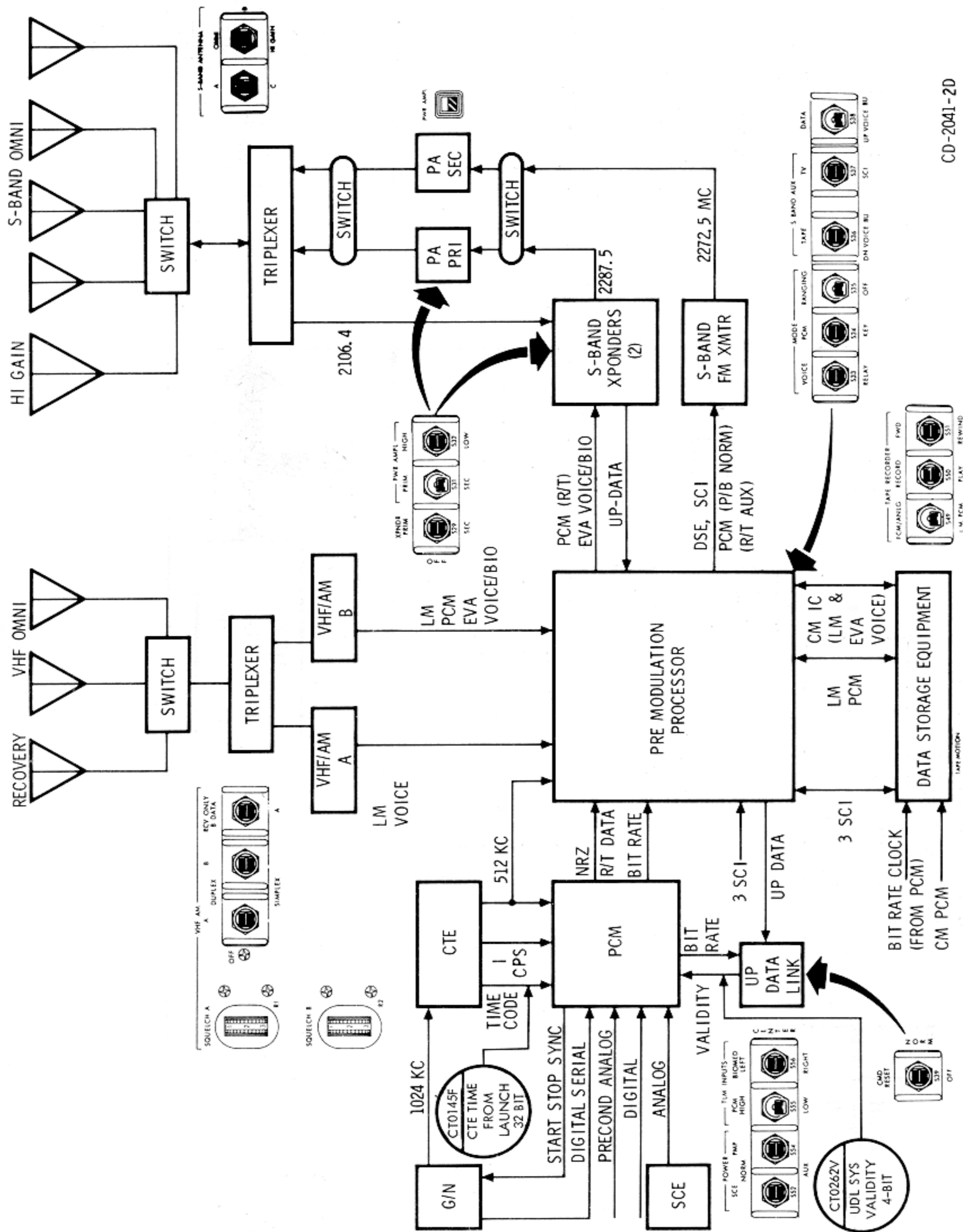

CD-2041-20

Figure 2.8-7. Data Interfaces

T/C

TELECOMMUNICATION SYSTEM

SYSTEMS DATA

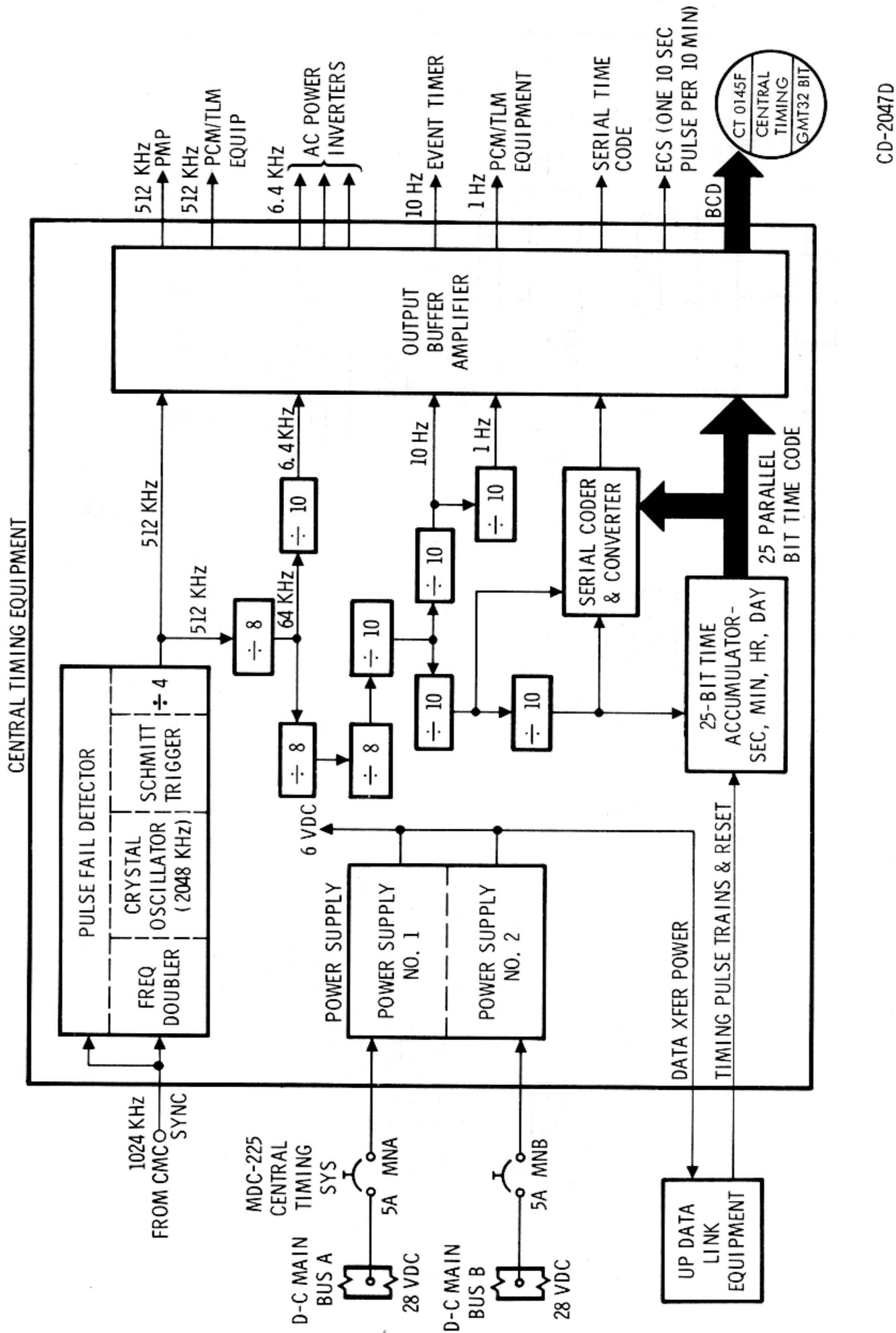

CD-2047D

Figure 2.8-8. Central Timing Equipment

SYSTEMS DATA

The timing signals generated by the CTE, and their applications, are listed in the CTE outputs charts.

CTE OUTPUTS

Signal	Destination	Purpose
512-kc sq wave	PCM	SYNC of internal clock
512-kc sq wave	PMP	Modulating signal for S-band emergency key transmission
6 4-kc sq wave	EPS inverters (3)	Sync of 400-cycle a-c power
10-cps sq wave	Digital event timer	Pulse digital clock
1-cps sq wave	PCM	PCM frame sync
1 pulse per 10 minutes	ECS	Discharge water from astronaut suit
25-bit parallel time code output	PCM	Time correlation of PCM data
Serial time code output (3)	Scientific data equipment	Time correlation of data

T/C

2.8.3.3.5 Signal Conditioning Equipment (SCE).

The signal conditioning equipment (SCE) is contained in a single electronics package located in the LEB. (See figure 2.8-9.) Its functions are to convert various kinds of unconditioned signals from the instrumentation equipment into compatible 0- to 5-volt d-c analog signals, and to provide excitation voltages to some of the instrumentation sensors and transducers.

The SCE contains the following modules:

- DC differential amplifier assembly
- DC differential bridge amplifier assemblies
- AC to DC converter assembly
- DC active attenuator assembly
- Power supply +20 vdc, -20 vdc, +10 vdc, +5 vdc
- Redundant power supply - +20 vdc, -20 vdc, +10 vdc, +5 vdc.

TELECOMMUNICATION SYSTEM

SYSTEMS DATA

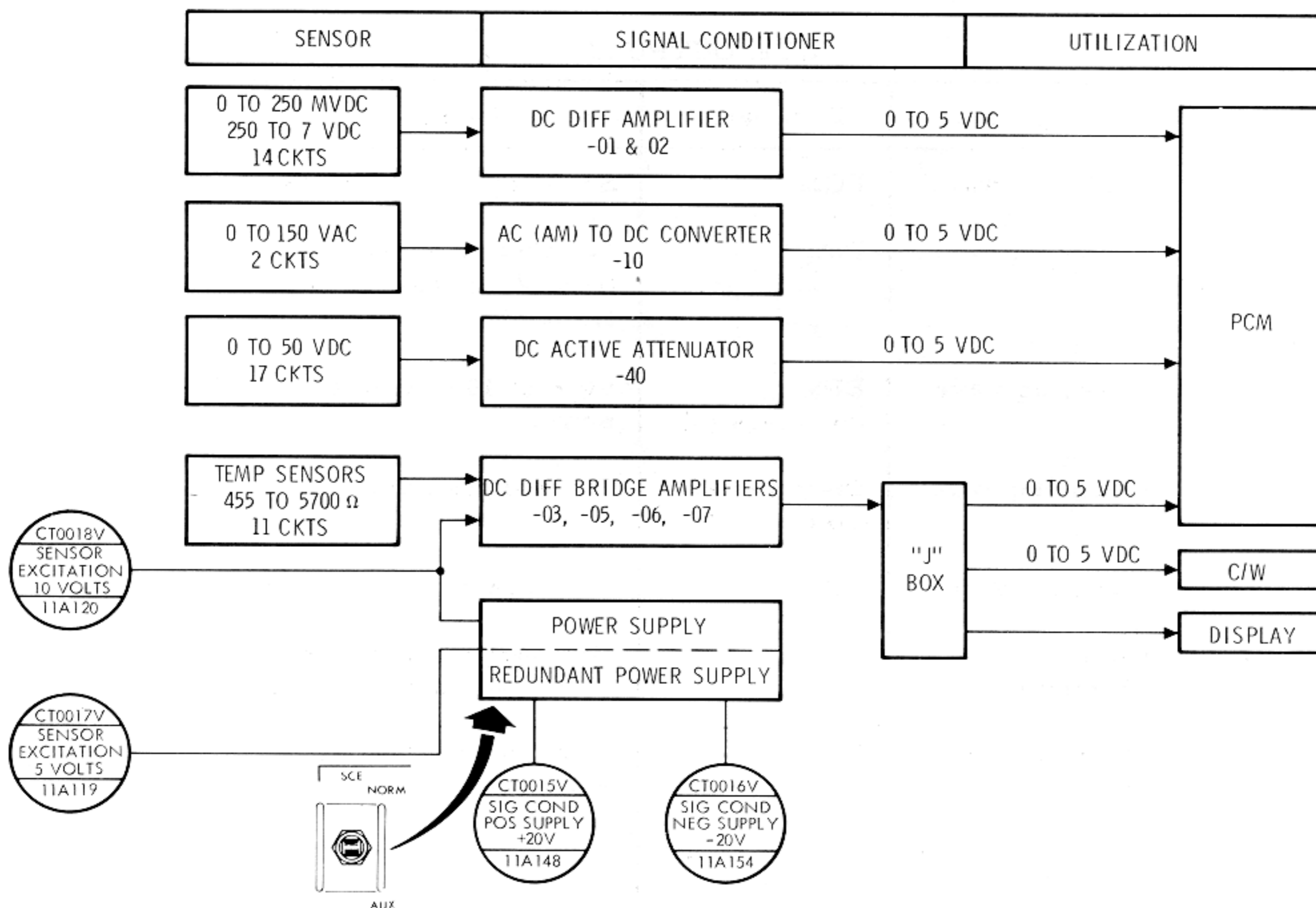

CD-2045C

Figure 2.8-9. Signal Conditioning Equipment

The only external control for the SCE is the 3-position SCE switch on MDC-3. The NORMAL position energizes the primary power supply and an error detection circuit. If the primary power supply voltages go out of tolerance, the error detection circuit automatically switches the SCE to the redundant power supply. The SCE will not automatically switch back to the primary once it has switched to the redundant unless power is interrupted.

The AUX position provides for manual switching between the power supplies. This is accomplished by repeated selection of the AUX position.

The SCE requires 28-volt d-c power input and consumes about 35 watts.

SYSTEMS DATA

Figure 2.8-9 shows graphically the input and outputs of the SCE and its redundant power supply.

2.8.3.3.6 Pulse-Code Modulation Telemetry (PCM TLM) Equipment.

The function of the PCM TLM equipment (figure 2.8-10) is to convert TLM data inputs from various sources into one serial digital output signal. This single-output signal is routed to the PMP for transmission to the MSFN or to the DSE for storage. The PCM TLM equipment is located in the lower equipment bay. Input signals to the PCM TLM equipment are of three general types: high-level analog, parallel digital, and serial digital.

Two modes of operation are possible: the high (normal) bit-rate mode of 51.2 kilobits per second (kbps) and the low (reduced) bit-rate mode of 1.6 (kbps). Operational mode is selected by placing the TLM INPUTS-PCM switch on MDC-3 to HIGH or LOW, as applicable. When the switch is in the LOW position, the high-PCM bit-rate can be commanded by the MSFN via the UDL equipment. The PCM requires about 21 watts of 3-phase 115/200-volt 400-cps a-c power. Internal signal flow of the PCM is shown in figure 2.8-10.

The analog multiplexer can handle 365 high-level analog inputs in the high-bit-rate mode. Four of these signals, 22A1-4, are sampled at 200 SPS; 16 signals, 12A1-16, are sampled at 100 SPS; 15 signals, 51A1-15, are sampled at 50 SPS; 180 signals, 11A1-180, are sampled at 10 SPS; and 150 signals, 10A1-150, are sampled at 1 SPS.

These analog signals are gated through the multiplexer, the high-speed gates, and are then fed to the coder. In the coder, the 0- to 5-volt analog signal is converted to an 8-bit binary digital representation of the sample value. This 8-bit word is parallel-transferred into the digital multiplexer where it is combined with 38 external 8-bit digital parallel inputs, and 5 internal ones, to form the majority of the output format.

The external digital parallel inputs fall into three groups. The first group contains two 8-bit word inputs sampled at 200 S/S at the high-bit rate only. The second group contains a single 8-bit word input sampled at 50 S/S at the high bit rate and 10 S/S at the low bit rate. The third, and largest, group contains 35 eight-bit word inputs sampled at 10 S/S at the high-bit rate and one S/S at the low-bit rate. The remaining inputs to the digital multiplexer are internal and come from the coder, sync format, and programmer of the PCM.

This digital parallel information is parallel-transferred into the output register where it is combined with the digital serial input, and then outputted serially into the data transfer buffer. From here the information is passed on to the premodulation processor for preparation for transmission over the RF equipment.

TELECOMMUNICATION SYSTEM

SYSTEMS DATA

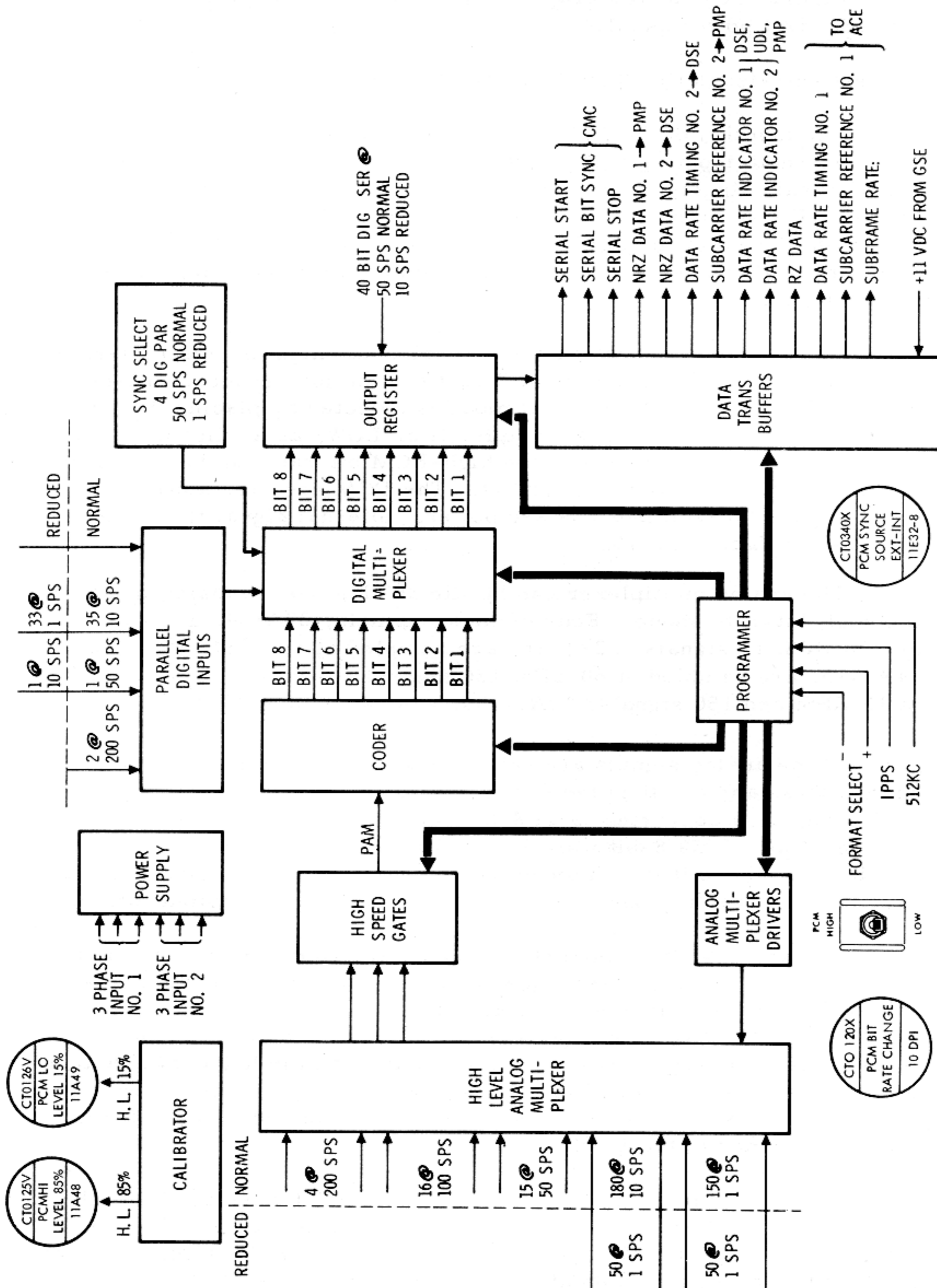

CD-2046C

Figure 2.8-10. PCM Block Diagram

TELECOMMUNICATION SYSTEM

SYSTEMS DATA

The PCM receives 512-kc and 1-cps timing signals from the central timing equipment. If this source fails, the PCM programmer uses an internal timing reference. The timing source being used is telemetered. Two calibration voltages are also telemetered as a confidence check of the PCMs overall operation.

The PCM requires about 21 watts of 3-phase 400-cycle power for its redundant power supplies.

2.8.3.3.7 Television (TV) Equipment.

The TV equipment consists of a small, portable TV camera that can be hand-held, or mounted in the locations shown in figure 2.8-11. Its function is to acquire real-time video information for transmission to the MSFN. The camera is connected to a 12-foot cable for use throughout the CM. The cable is connected to the power connector J395 and coax connector J122 on the aft side of the right-hand forward equipment bay. See figure 2.8-12 for physical dimensions.

The camera is controlled by an ON/OFF switch on the camera handle and an automatic light control switch on the back. Power is supplied to the cameras ON/OFF switch through CB13 located on RHEB-225 when the S-BAND AUX TAPE/VOICE B4 switch (MDC-3) is in the OFF position and the S-BAND AUX TV/SCI switch (MDC-3) is in the TV position. Power required by the camera is 6.75 watts at 28 volts dc.

The composite video signal is sent from the camera to the premodulation processor where it is then sent to the S-band FM transmitter and its associated power amplifier for transmission to the MSFN and to the SM umbilical for hardline communications before lift-off.

The color TV equipment consists of a small, portable color TV camera that can be hand-held, or mounted in the locations shown in figure 2.8-12A. One of the camera functions is to acquire real-time color video information for transmission to the MSFN. The camera's primary function is its use during rendezvous and docking operations. During this period of operation it will be mounted at the right-hand rendezvous window. A TV monitor is used with the color TV camera for astronaut viewing of TV operations. See figure 2.8-12B for details of camera and monitor. The color TV camera is compatible with the present black and white TV system in relation to power connections and switch controls.

T/C

SYSTEMS DATA

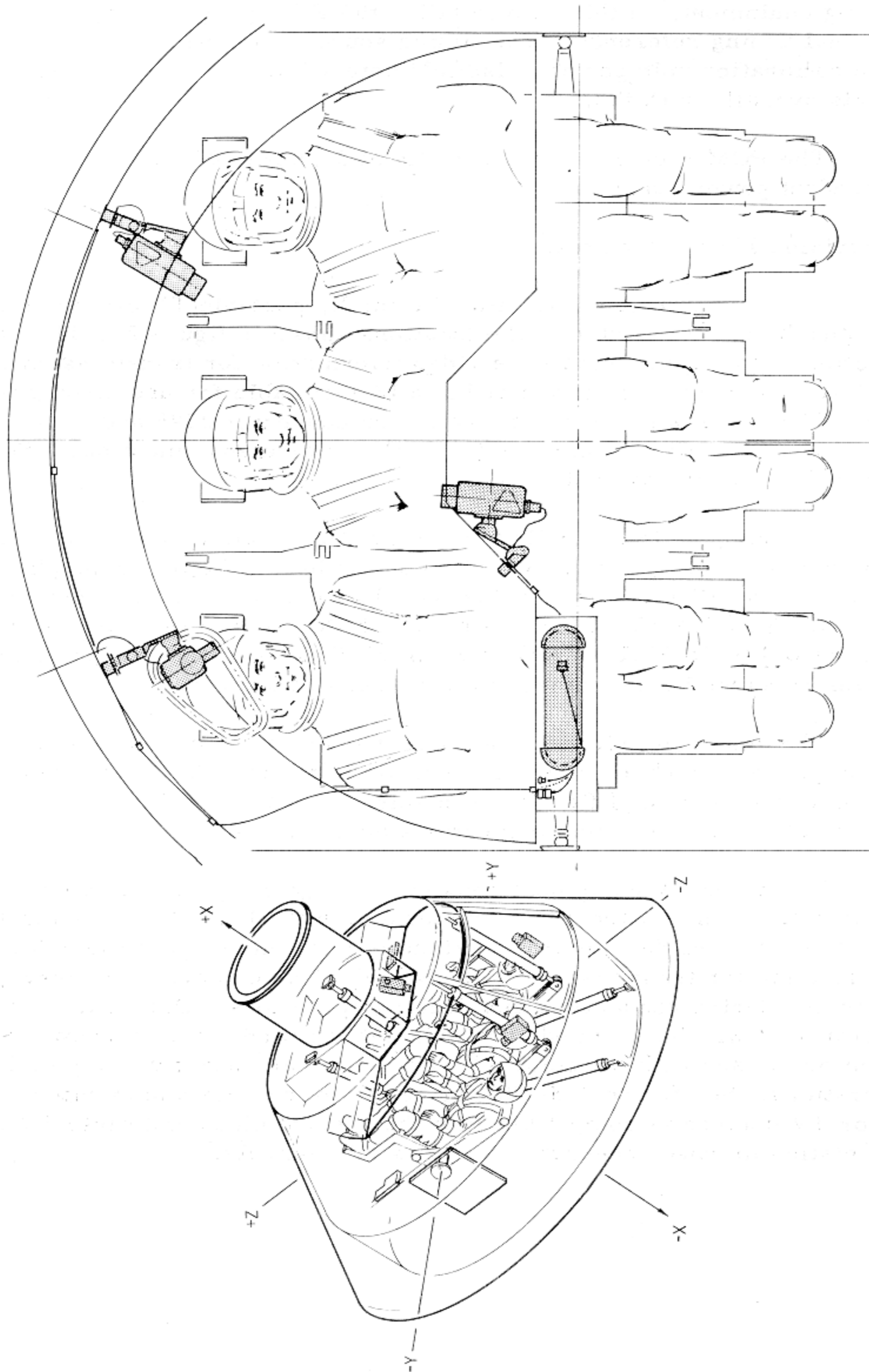

CP-2012C

Figure 2.8-11. Television Camera Locations

TELECOMMUNICATION SYSTEM

SYSTEMS DATA

2.8.3.3.8 Data Storage Equipment (Figure 2.8-13).

The data storage equipment provides for the storage of data for delayed playback and/or recovery with the spacecraft. Information is recorded during powered flight phases, and when out of communication, is then played back (dumped) when over selected S-band stations.

- Location: lower equipment bay.

Electrical Power Requirements.

- Voltage input: 115-vac 3-phase 400-cps and/or 28-vdc
- Power input: 40 watts nominal, 70 watts maximum (3 seconds).

Tape Transport Characteristics.

- Tape speeds: 3.75, 15, and 120 ips
- Operational stability: Stable in less than 5 seconds

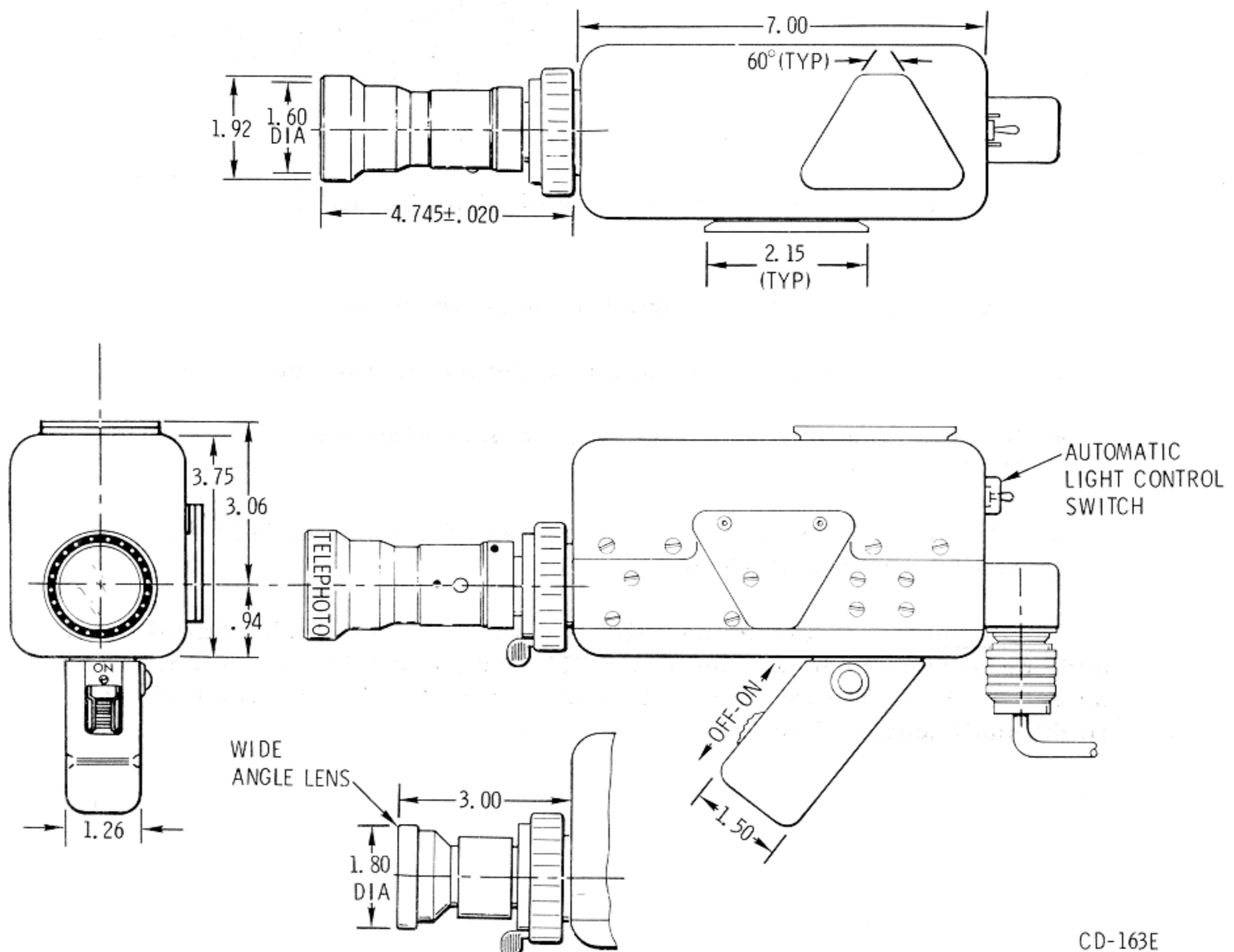

Figure 2.8-12. Television Camera

TELECOMMUNICATION SYSTEM

SYSTEMS DATA

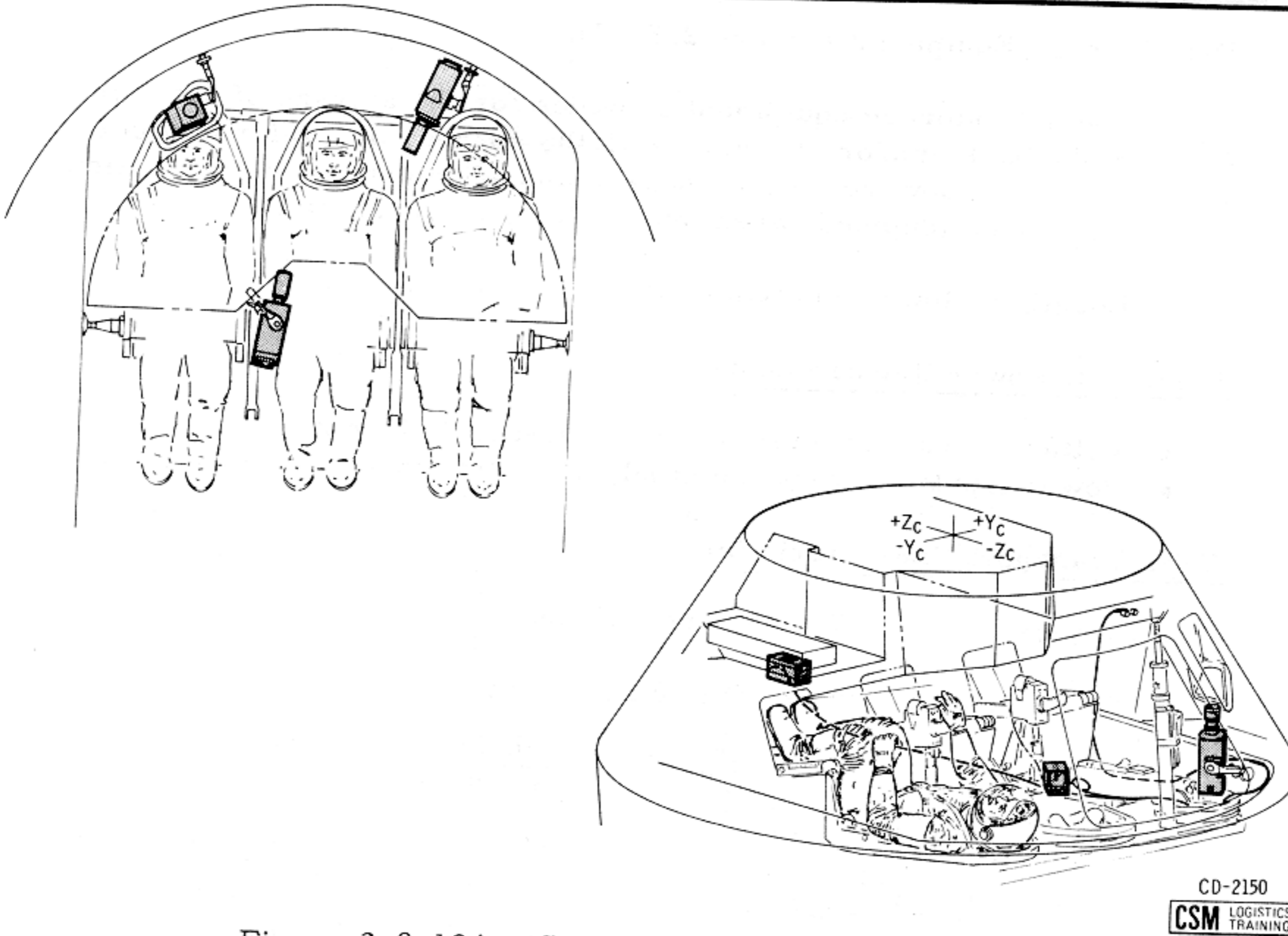

Figure 2.8-12A. Color TV and Monitor Locations

- Single directional: A rewind mode is provided.
- Automatic selection: Tape speed determined by data rate.
- Remote control: Complete remote operation possible via Up Data Link
- 2250 feet of tape giving record times of 2 hours at 3-3/4 ips and 30 minutes at 15 ips

Channels. Fourteen parallel tracks: four CM PCM digital data, and one of digital clock, one LM PCM data, one CM-LM voice, three scientific data, and four spare tracks. Spare tracks are available for flight qualification data.

SYSTEMS DATA

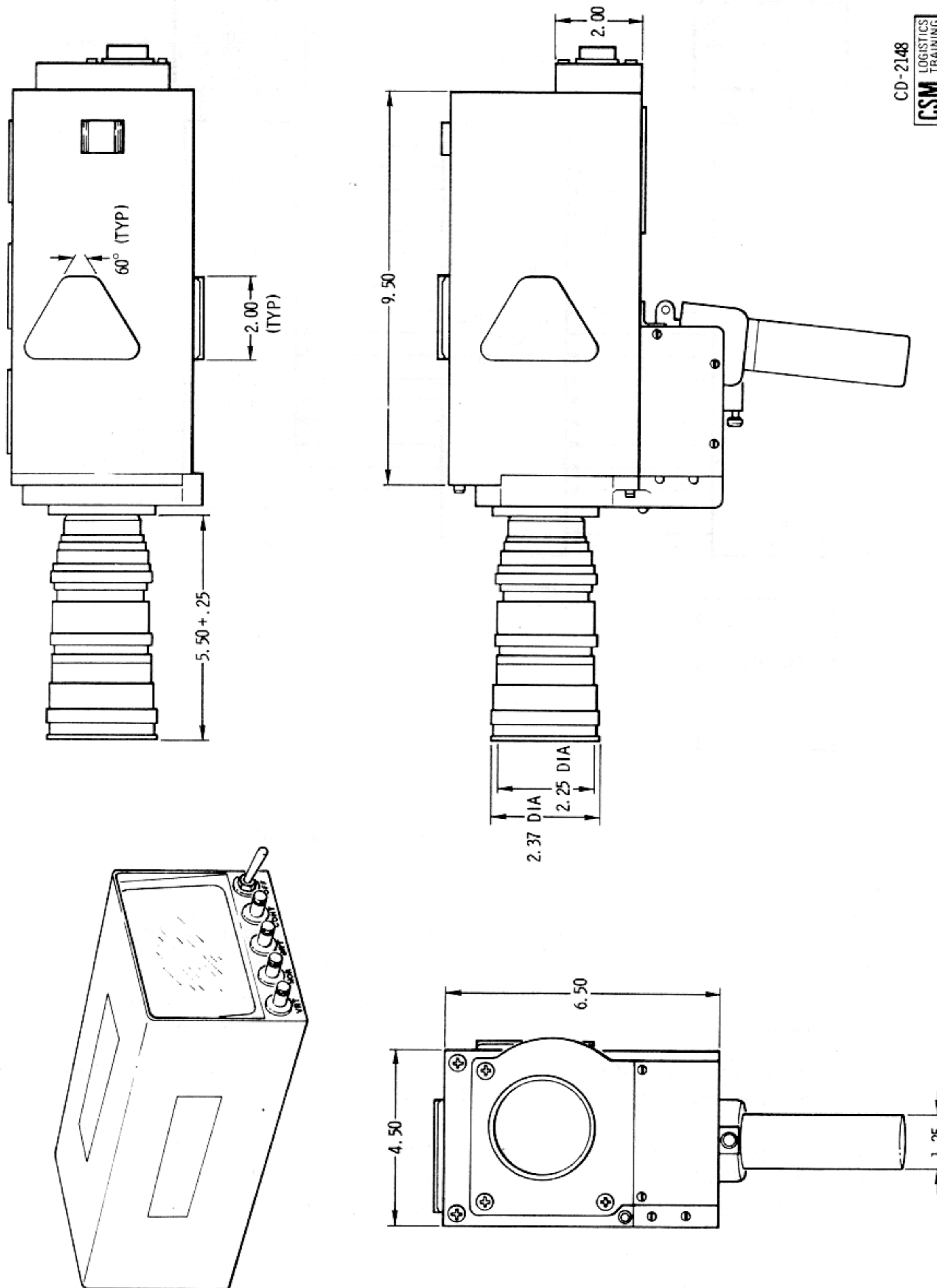
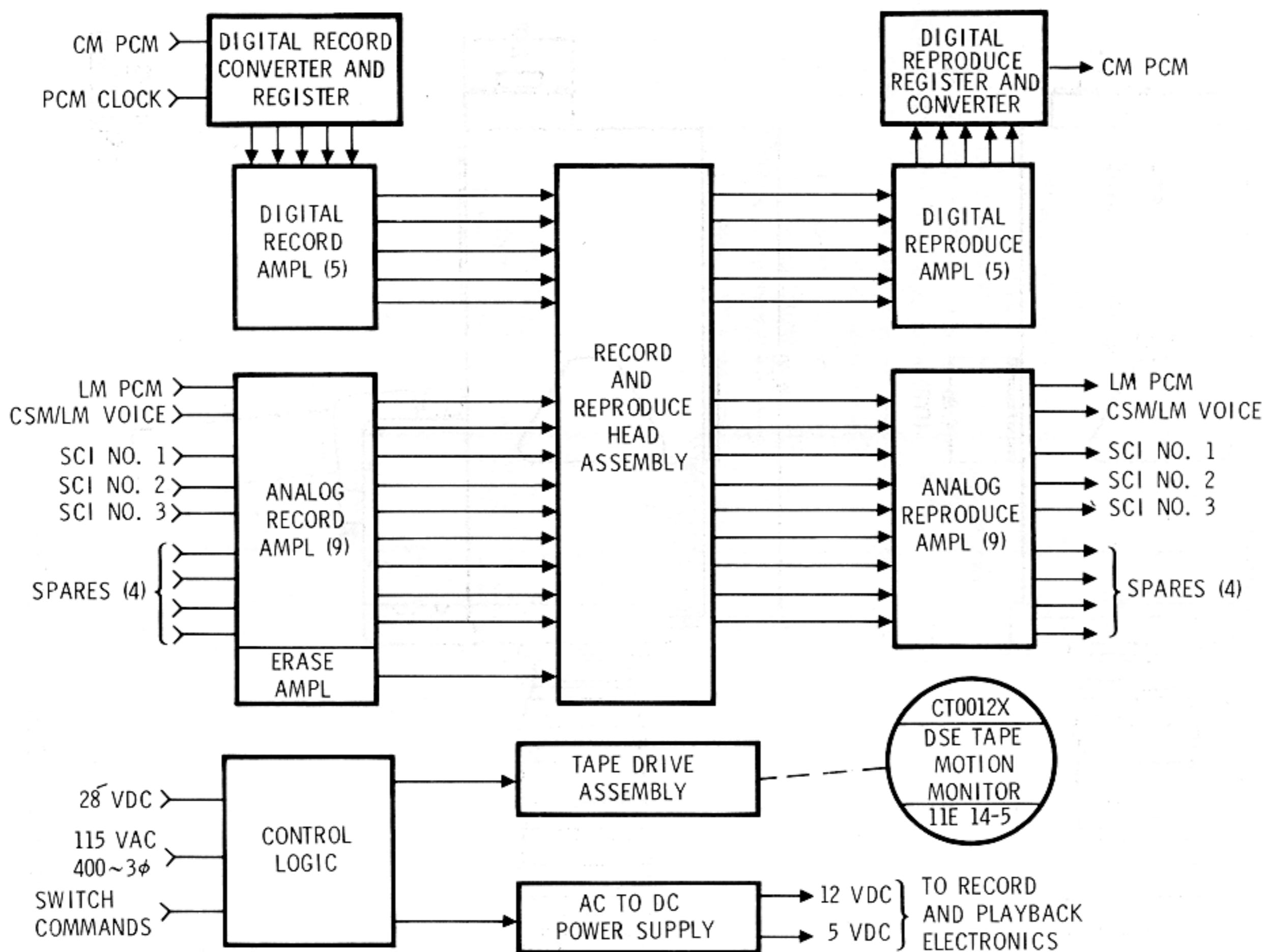

Figure 2.8-12B. Color TV Camera and Monitor

T/C

TELECOMMUNICATION SYSTEM

SYSTEMS DATA



CD-2111A

Figure 2.8-13. Data Storage Equipment

Digital Channels.

- a. Input parameters, serial to parallel conversion of the digital input is performed by the data storage equipment electronics:
 - Single serial NRZ, 51.2 kbs data train, and one 51.2-kc digital timing signal, recorded speed at 15 inches per second
 - Single serial NRZ, 1.6 kbs data train, and one 1.6-kc digital time signal, recorded at 3.75 inches per second
- b. Output parameters, parallel to serial conversion of the digital output is performed by the data storage equipment electronics.
- c. The playback rate of CM PCM is 51.2 kbs for data recorded at 3.75 ips or 15 ips. Playback speeds are 120 ips and 15 ips respectively.

The various operational capabilities and attendant switching positions are shown in the following list.

SM2A-03-BLOCK II-(1)
 APOLLO OPERATIONS HANDBOOK

SYSTEMS DATA

MDC-3 Switches	RECORD				PLAYBACK				REWIND
	LM PCM	3-SCI's	CSM PCM	LM/CSM Voice	LM PCM	3-SCI's	CSM PCM	LM/CSM Voice	
S-BAND AUX TAPE	Normally off	Normally off	Normally off	Normally off	TAPE	TAPE	TAPE	TAPE	Normally off
S-BAND AUX TV	N/A	Off or TV	N/A	N/A	Tape sw override	Tape sw override	Tape sw override	Tape sw override	N/A
VHF/AM A	Normally SIMPLEX	Normally SIMPLEX	Normally SIMPLEX	Normally SIMPLEX	N/A	N/A	N/A	N/A	N/A
VHF/AM RCV only	B DATA	N/A	N/A	Off	N/A	N/A	N/A	N/A	N/A
TAPE RECORDER/PCM/ANLG	N/A	N/A	N/A	N/A	LM PCM	PCM/ANLG	PCM/ANLG	PCM/ANLG	N/A
TAPE RECORDER/RECORD	RECORD	RECORD	RECORD	RECORD	PLAY	PLAY	PLAY	PLAY	Normally off
TAPE RECORDER/FWD	FWD	FWD	FWD	FWD	FWD after REWIND	FWD after REWIND	FWD after REWIND	FWD after REWIND	REWIND
TLM INPUT/PCM	N/A	N/A	High or low	N/A	N/A	N/A	N/A	N/A	N/A

Operational Switching (Figure 2.8-14).

External +28 vdc from the FLT BUS is applied to the TAPE RECORDER - FORWARD/REWIND switch. With this switch in the REWIND position, the tape transport will reverse at 120 ips. The FORWARD position of this switch will also run the tape transport in the forward direction at 120 ips if PLAY or RECORD is not selected. The FORWARD position of the TAPE RECORDER - FORWARD/REWIND switch supplies the excitation to the RECORD/PLAY switch in the FORWARD position. In the RECORD position, the record and erase circuitry is enabled and power is applied to the PCM-HIGH/LOW switch. The recording speed in the HIGH position is 15 ips and in the LOW position the speed is 3.75 ips. In the PLAY position, the reproduce circuitry is enabled and power is applied to the PCM/ANLG/LM PCM switch. The play speed in the PCM/ANLG position is internally selected, whereas the play speed in the LM PCM position is only at 120 ips.

All of the preceding switching functions may be accomplished by the use of real-time commands from the MSFN through the up-data (UDL) equipment.

T/C

SYSTEMS DATA

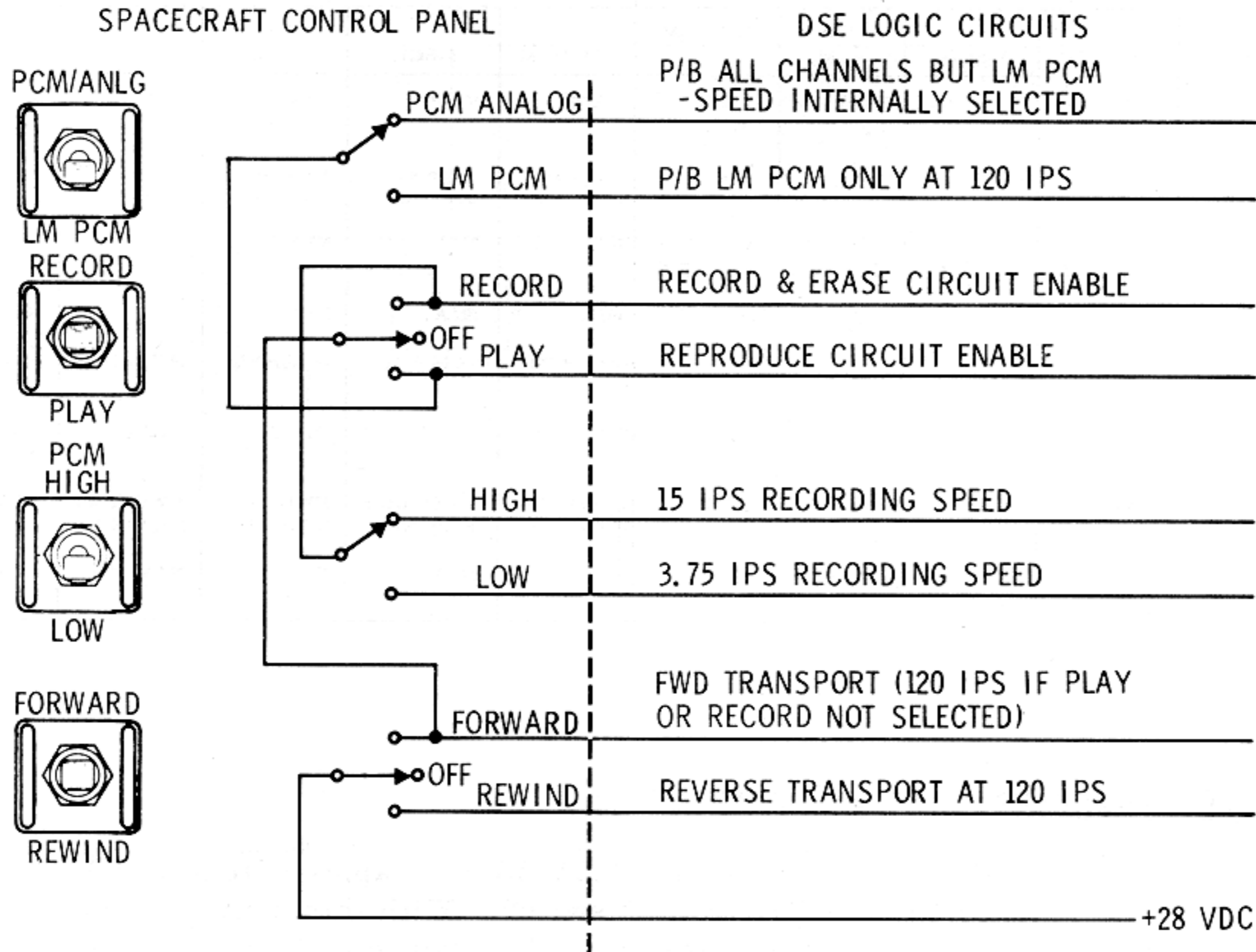

CD-2109A

Figure 2.8-14. DSE Simplified Switching Circuits

2.8.3.3.9 Up-Data Link (UDL) Equipment.

The function of the UDL equipment is to receive, verify, and distribute digital updating information sent to the SC by the MSFN at various times throughout the mission to update or change the status of operational systems. The UDL (figure 2.8-15) consists of detecting and decoding circuitry, a buffer storage unit, output relay drivers, and a power supply. The UDL provides the means for MSFN to update the CMC, the CTE, and to select certain vehicle functions. Up-data information is transmitted to the SC as part of the 2-kmc S-band signal. When this signal is received by USBE receiver, the 70-kc subcarrier containing the up-data information is extracted and sent to the up-data discriminator in the PMP. The resulting composite audio frequency signal is routed to the sub-bit detector in the UDL which converts it to a serial digital signal. The digital

SYSTEMS DATA

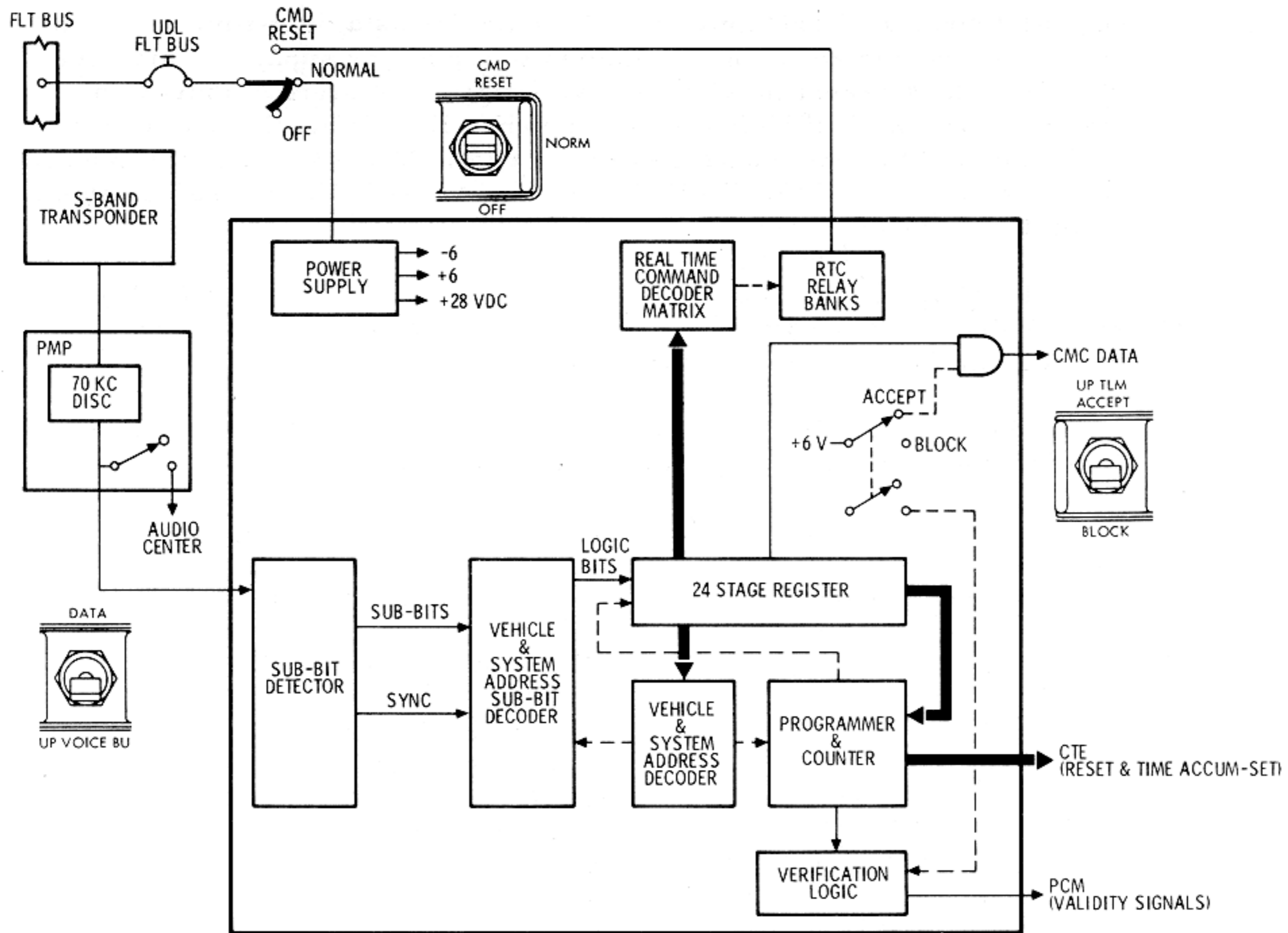

CD-2049D

Figure 2.8-15. Up-Data Link Equipment

output from the sub-bit detector is fed to the remaining UDL circuitry, which checks and stores the digital data, determines the proper destination of the data, and transfers it to the appropriate SC system or equipment. The UDL has three controls: two are on MDC-3 under the UP-TLM bracket and the third on MDC-2. The first, a two-position switch, is the DATA-VOICE BU switch. In the DATA position, the 70-kc subcarrier information is routed to the UDL equipment for normal processing. The VOICE BU position routes the 70-kc subcarrier information to the UDL equipment and audio centers, thus providing an alternate path for voice information to be sent in case of failure of the 30-kc subcarrier discriminator.

T/C

SYSTEMS DATA

The second switch is the CMD RESET/NORMAL/OFF switch. The center, NORMAL, position applies power to the UDL and permits normal operation. The upward position performs a real-time command reset function and keeps power applied to the power supply. This resets all RTC relays except those relays affecting the system A abort light and the crew alarm, so the affected equipment will resume the operational mode dictated by their control switches on the MDC-3. The OFF position removes the power from the UDL equipment. The UDL consumes about 12 watts of 28-vdc power.

The third control, on MDC-2 by the DSKY, is labeled UP-TLM ACCEPT-BLOCK. This two-position switch blocks or routes the UDL message in the command module computer.

The following list gives the real-time commands and their functions. Some functions require two separate commands.

BLOCK II UDL REAL-TIME COMMANDS

<u>Real-Time Commands</u>	<u>Functions</u>
01	Abort Light (System A) On
00	Abort Light (System A) Off
07	Abort Light (System B) On
06	Abort Light (System B) Off
05	Crew Alarm On
04	Crew Alarm Off
02, 17	Spare
03, 12	Spare
03, 13	Spare
02, 16	*Spare
22, 27	S-Band Ranging On
23	S-Band Ranging Off
22, 26	*Astronaut Control (S-Band Ranging)
32, 37	S-Band PCM Mode On
33, 37	S-Band PCM Mode Off
32, 36	*Astronaut Control (S-Band PCM Mode)
42, 47	S-Band P. A. High On
43, 46	S-Band By-Pass Mode
43, 47	S-Band P. A. Low On
42, 46	*Astronaut Control (S-Band P. A. Mode)
52, 57	Tape Playback PCM/Analog Mode
53	Tape Playback LEM/PCM Mode
52, 56	*Astronaut Control (Tape Playback Mode)
62, 67	Tape Recorder - Record Mode
63, 66	Tape Recorder - Off Mode

*Resets previously set relays so that equipment returns to mode shown on control panels.

SYSTEMS DATA

Real-Time Commands

Functions

63, 67	Tape Recorder - Playback Mode
62, 66	*Astronaut Control (Tape Recorder Playback/Record Selection)
72, 77	Tape Recorder - Transport Forward
73, 76	Tape Recorder - Power Off
73, 77	Tape Recorder - Transport Rewind
72, 76	*Astronaut Control (Tape Transport)
65	PCM Data Rate Low
64, 71	PCM Data Rate High
64, 70	*Astronaut Control (PCM Data Rate)
41, 45	S-Band Tape Mode
41, 44	S-Band Tape Off
40, 51	S-Band Back-Up Down Voice
40, 50	*Astronaut Control (S-Band)
75	D OMNI Antenna ON
74	Astronaut Control (S-Band Antenna)

*Resets previously set relays so that equipment returns to mode shown on control panels.

2.8.3.4 RF Electronics Equipment Group.

The RF electronics equipment group includes all T/C equipment which functions as RF transmitters or receivers. The antennas used by this equipment are mentioned only briefly in this paragraph. Refer to paragraph 2.8.3.5 for more information on the antennas.

2.8.3.4.1 VHF/AM Transmitter-Receiver Equipment (Figure 2.8-16).

The VHF/AM transmitter-receiver equipment provides the capability for the following:

- Two-way voice communications with MSFN, LM, EVA, and recovery forces.
- Relay of two-way voice from either LM or EVA to MSFN (via S-band/MSFN link)
- Ranging with the LM
- Reception of PCM data from LM
- Reception of biomed from EVA.

TELECOMMUNICATION SYSTEM

SYSTEMS DATA

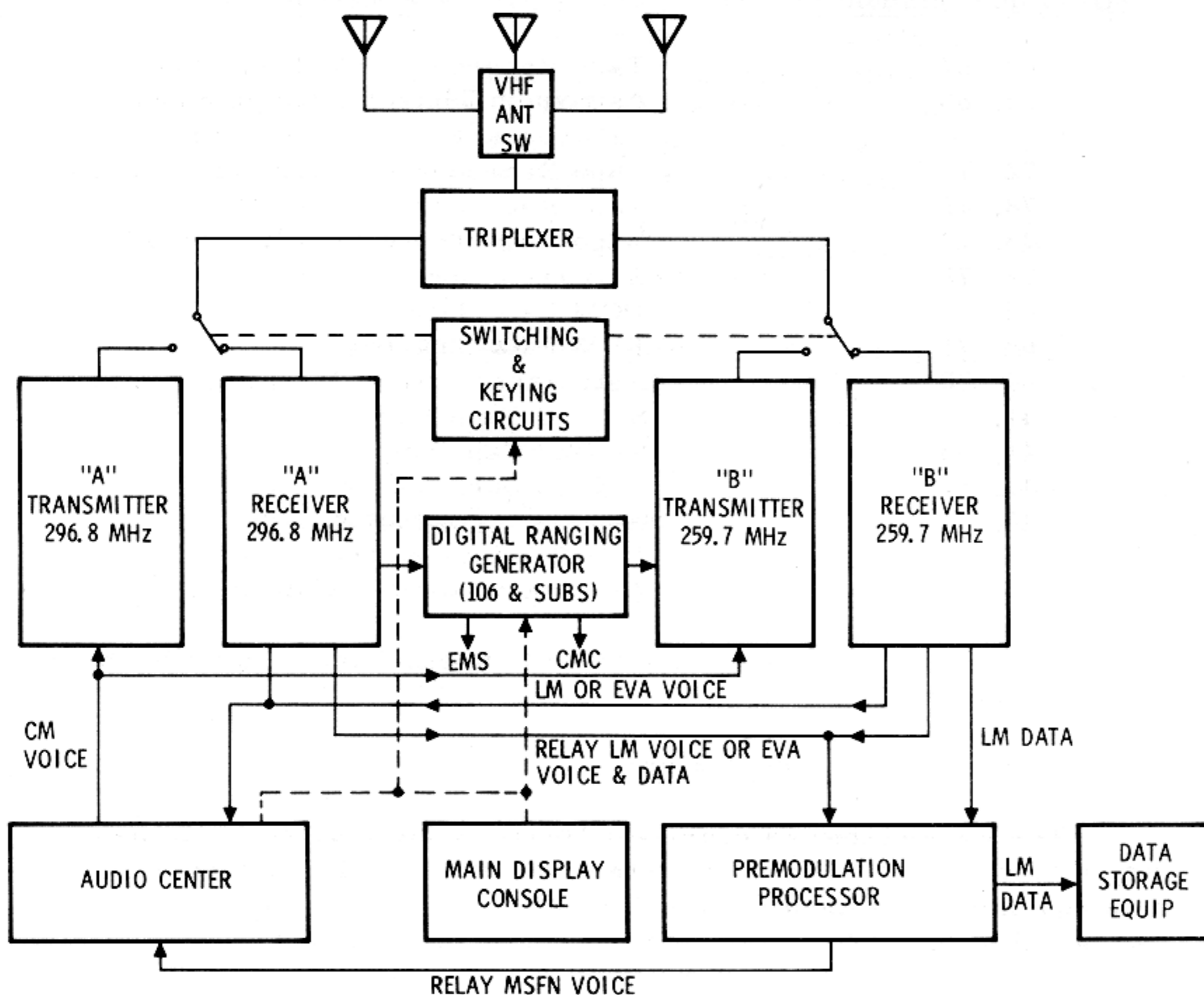

CD-2125

Figure 2.8-16. VHF-AM Block Diagram

The equipment is contained in a single enclosure consisting of 11 sub-assemblies, 2 coax relays, and 2 bandpass filters mounted within a three-piece hermetically sealed case in the lower equipment bay.

The equipment group provides two independent VHF/AM transmitters and two independent VHF/AM receivers. One transmitter and receiver will provide for transmission and reception of voice communications on a preassigned frequency of 296.8 mc. One transmitter and receiver will provide for transmission of voice communications or reception of voice communications and data on a preassigned frequency of 259.7 mc. Complete isolation of the receiver circuits up to the final common outputs is provided. A short or open on any output will not degrade the other outputs.

SYSTEMS DATA

Various modes of operation are possible in both the simplex and duplex configurations:

- Simplex A - Transmit and receive on 296.8 mc for voice only
- Simplex B - Transmit and receive on 259.7 mc for voice only
- Duplex A - Transmit on 296.8 mc and receive on 259.7 mc for voice and biomed data
- Duplex B - Transmit on 259.7 mc and receive on 296.8 mc for voice and ranging
- Receive A - Receive on 296.8 mc only
- Receive B - Receive LM data on 259.7 mc only
- Relay - Interfaces with S-band system for relay to MSFN.

These modes may also be used as a backup VHF recovery beacon transmitting on 296.8 or 259.7 mc.

The VHF/AM transmitter-receiver is controlled by the VHF-AM controls on panel No. 3 of the main display console (S43, S44, and S71). The DUPLEX-off-SIMPLEX switches activate the receivers and transmitters by applying 28-volt d-c power. About 6 watts of power are required in these modes with the transmitter in standby and about 36 watts when keyed. In the OFF position, no power will be supplied to the equipment. The RCV ONLY B DATA/OFF/A switch activates the receivers only. When the A position is selected, about 2 watts of 28-volt d-c power are supplied to the 296.8-mc receiver. When the B DATA position is selected, about 2 watts of 28-volt d-c power are supplied to the 259.7-mc receiver and the LM data amplifier.

After being selected, the VHF/AM transmitters can be enabled either by voice-operated relay (VOX) or by manually depressing the XMIT switch on the comm cable or rotational controller. The squelch control varies the level of squelch sensitivity and is located on panel 3 of the main display console.

The transmitters and receivers interface with the main display console (power control), the audio center (audio inputs, outputs and PTT functions), and the triplexer (RF inputs and outputs). The equipment is connected through the triplexer and antenna control switch to either of the VHF omniantennas in the service module or the VHF recovery antenna No. 2 in the command module.

TELECOMMUNICATION SYSTEM

SYSTEMS DATA

2.8.3.4.2 Digital Ranging Generator (VHF Ranging).

The function of the VHF ranging system is to aid lunar rendezvous of the CSM with the LM. This is a backup system and will be needed only if the LM radar fails, or the LM propulsion system would prove incapable of effecting rendezvous. This system uses the existing VHF/AM equipment, and incorporates the use of a digital ranging generator (DRG).

- Location: Lower Equipment Bay
- Electrical Power Requirements

Voltage input: 28 vdc
Power input: 25 watts

- Mechanical Characteristics

Weight: 7.0 pounds
Volume: 200 cubic inches (approximately)

The DRG generates a tone for transmission over the VHF/AM 259.7-mc transmitter, and receives the turn-around range tone from the LM via the VHF/AM 296.8-mc receiver. A range tracker, in the DRG, will compute the range by comparing the difference between the transmitted and received tone, and display this range, real-time, on the entry monitoring system (EMS). In addition, the range data will also be sent to the command module computer (CMC), at a rate of once a minute, initiated by a command from the CMC. This information will be displayed on the DSKY. Both displays will be shown in units of 1/100-nautical mile.

This system is activated by turning on the VHF RANGING switch, on MDC-3. This switch applies +28-vdc power to the DRG, as well as applying a ground to the keying circuit to key the VHF/AM 259.7-mc transmitter, for ranging tone transmission. If the TRACKER alarm light on the DSKY comes ON, this indicates that the data on the DSKY is incorrect. At the same time the display on the EMS will be reset to read zero. To restart ranging, the VHF RANGING—RESET-NORMAL switch, on the commander's audio center panel, is put to RESET, the acquisition phase is started, and tracking will be established.

2.8.3.4.3 Unified S-Band Equipment (USBE).

The USBE (figure 2.8-17) consists of two transponders, an FM transmitter, and power supply contained in a single electronic package in the lower equipment bay. The USBE will be used for voice communications, tracking and ranging, transmission of PCM data, and reception of up-data. The USBE also provides the sole means for transmission of TV.

SYSTEMS DATA

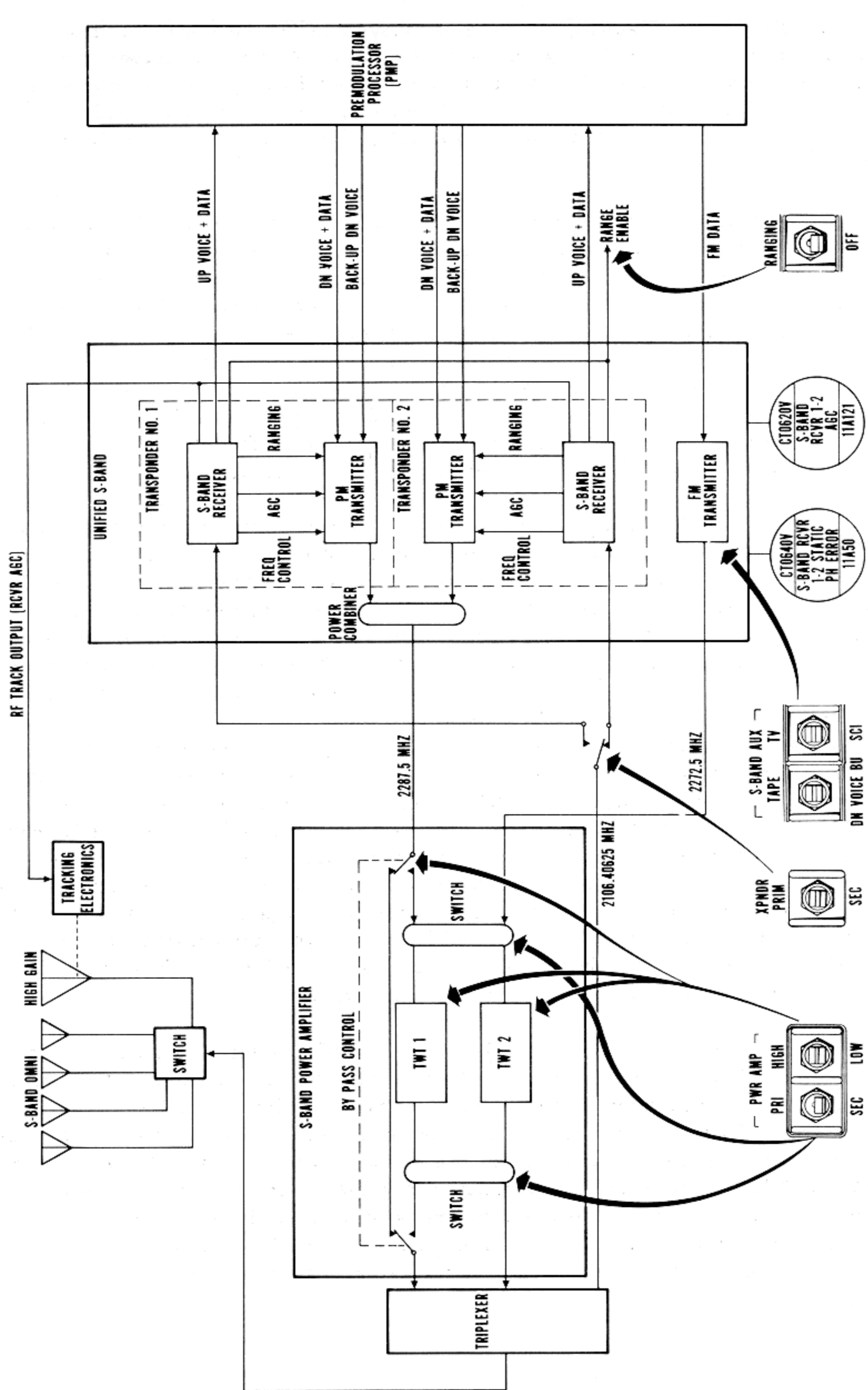

CO-2055F

Figure 2.8-17. Unified S-Band Equipment

T/C

TELECOMMUNICATION SYSTEM

SYSTEMS DATA

The USBE tracking method employed is the two-way or double-doppler method. In this technique, a stable carrier of known frequency is transmitted to the SC where it is received by the phase-locked receiver, multiplied by a known ratio, and then re-transmitted to the MSFN for comparison. Because of this capability, the USBE is also referred to as the S-band transponder.

For determining SC range, the MSFN phase-modulates the transmitted carrier with a pseudo-random noise (PRN) binary ranging code. This code is detected by the SC USBE receiver and used to phase-modulate the carrier transmitted to the MSFN. The MSFN receives the carrier and measures the amount of time delay between transmission of the code and reception of the same code, thereby obtaining an accurate measurement of range. Once established, this range can be continually updated by the double-doppler measurements discussed earlier. The MSFN can also transmit up-data commands and voice signals to the SC USBE by means of two subcarriers: 70 kc for up-data and 30 kc for up-voice.

The USBE transponder is a double-superheterodyne phase-lock loop receiver that accepts a 2106.4-mc, phase-modulated RF signal containing the up-data and up-voice subcarriers, and a pseudo-random noise (PRN) code when ranging is desired. This signal is supplied to the receiver (figure 2.8-18) via the triplexer in the S-band power amplifier equipment and presented to three separate detectors: the narrow band loop phase detector, the narrow band coherent amplitude detector, and the wide band phase detector. In the wide band phase detector, the 9.531-mc IF is detected; and the 70-kc up-data and 30-kc up-voice subcarriers are extracted, amplified, and routed to the up-data and up-voice discriminators in the PMP equipment. Also, when operating in a ranging mode, the PRN ranging signal is detected, filtered, and routed to the USBE transmitter as a signal input to the phase modulator. In the loop-phase detector, the 9.531-mc IF signal is filtered and detected by comparing it with the loop reference frequency. The resulting d-c output is used to control the frequency of the 19.0625-mc voltage-controlled oscillator (VCO). The output of the VCO is used as the reference frequency for receiver circuits as well as for the transmitter.

The coherent amplitude detector (CAD) provides the automatic gain control (AGC) for receiver sensitivity control. In addition, it detects the amplitude modulation of the carrier introduced by the high-gain antenna system. This detected output is returned to the antenna control system to point the high-gain antenna to the earth station. An additional function of the CAD is to select the auxiliary oscillator to provide a stable carrier for the transmitter, whenever the receiver loses lock. The AGC circuitry also supplies a signal to the S-BAND ANT S-meter located on the lower right on MDC-2. A received relative signal strength is indicated by this meter.

SYSTEMS DATA

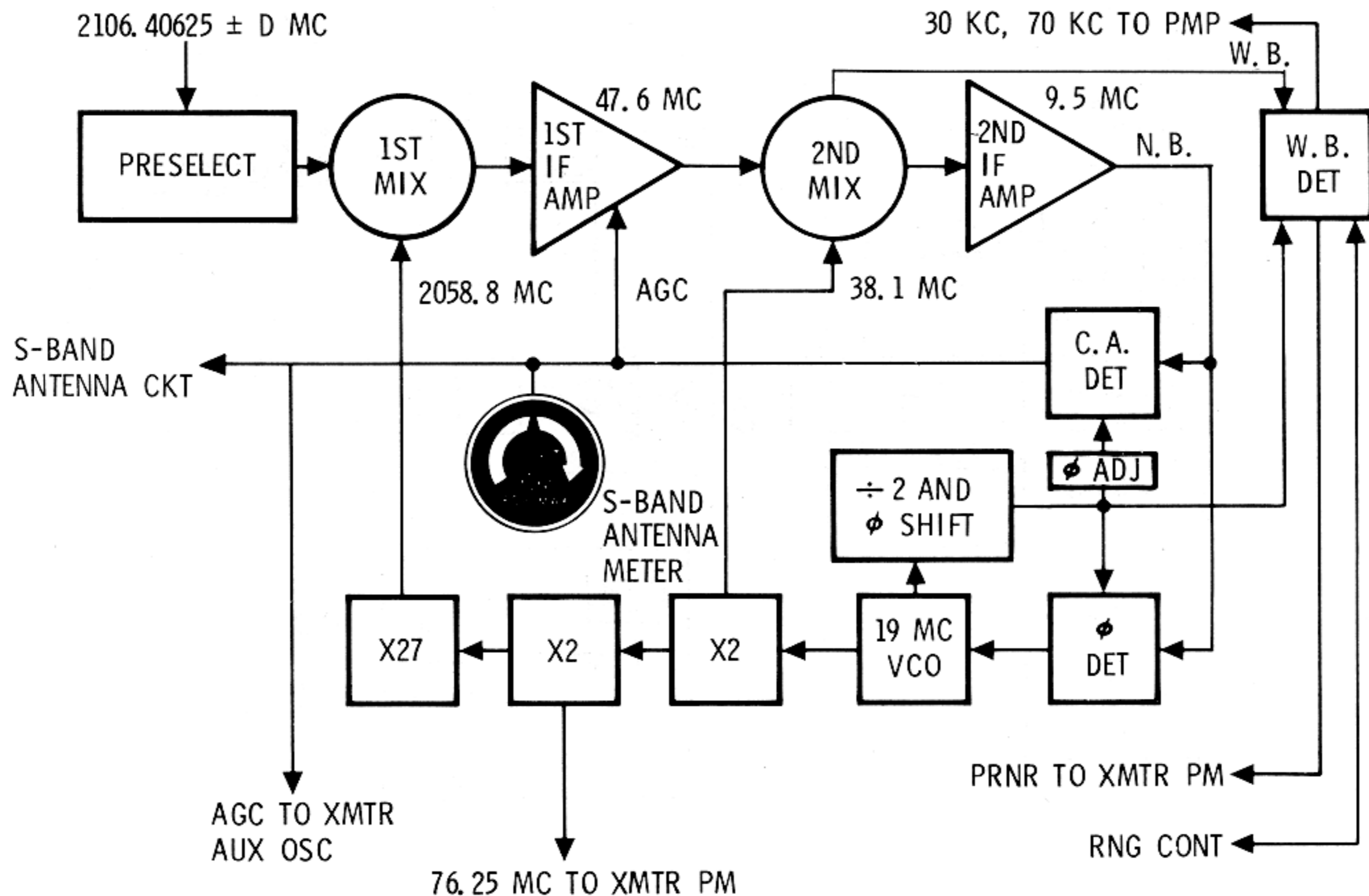

CD-2078B

Figure 2.8-18. S-Band Receiver

The USBE transponders are capable of transmitting a 2287.5-mc phase-modulated signal. The initial transmitter frequency is obtained from one of two sources: the VCO in the phase-locked USBE receiver or the auxiliary oscillator in the transmitter. Selection of the excitation is controlled by the CAD. If ranging has been selected, the up-link information is routed from the receiver wide band detector to the phase modulator in the transponder transmitter (figure 2.8-19). The phase modulator also can receive premodulated CSM voice and PCM data from the PMP in a normal mode or backup voice in event of a malfunction. The phase modulator signal is amplified to 3 watts by a power amplifier and sent into a X30 variactor multiplier, where much of this power is dissipated. The final power output through the power combiner is about 250 mw. About 20 watts of 3-phase 400-cycle a-c power and 2 watts of 28-vdc power are required by each transponder.

SM2A-03-BLOCK II-(1)
 APOLLO OPERATIONS HANDBOOK

SYSTEMS DATA

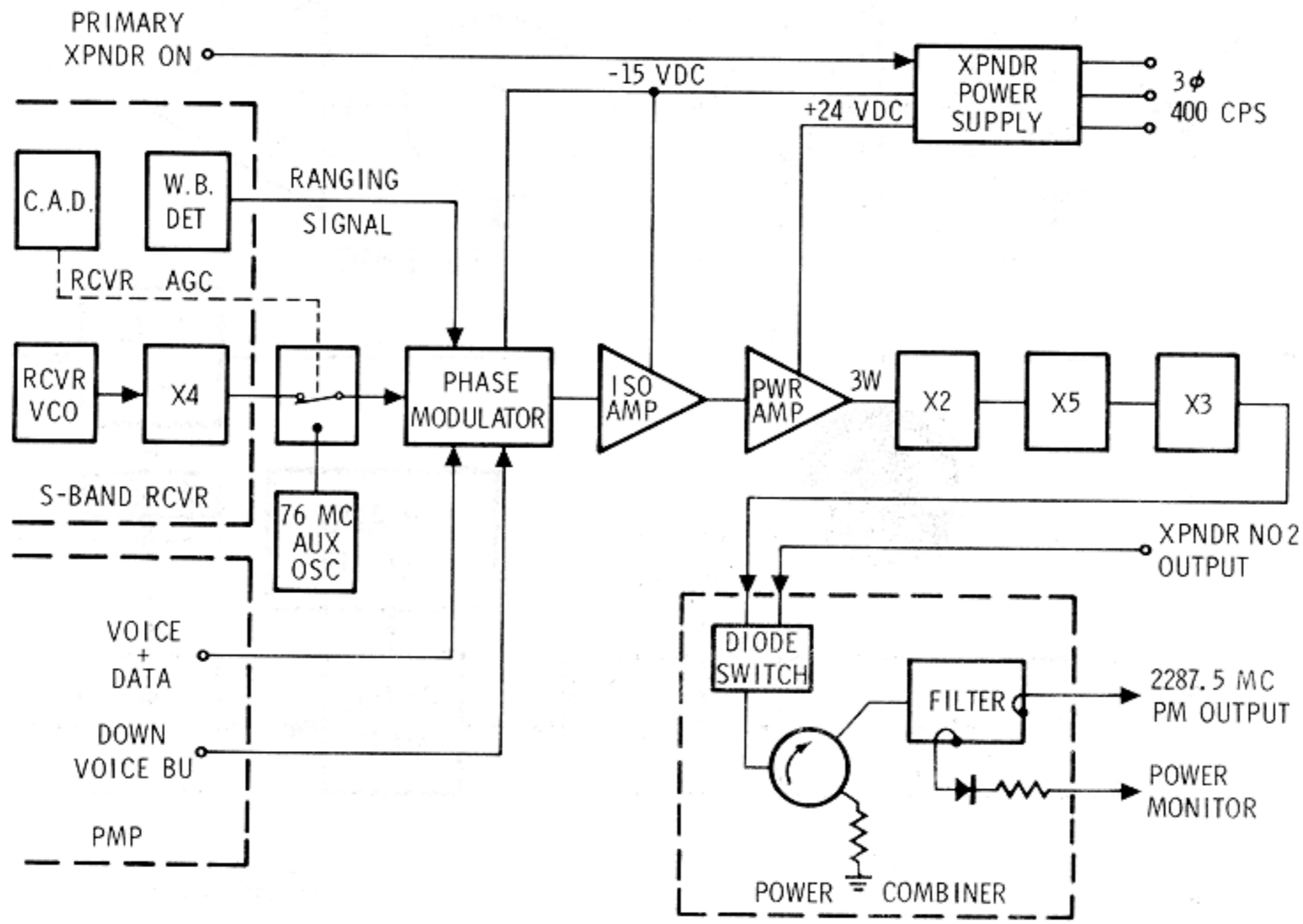

CD-2081C

Figure 2.8-19. S-Band PM Transmitter

The USBE also contains a separate FM transmitter which operates at 2272.5 mc (figure 2.8-20). This separate S-band transmitter permits time-shared scientific, television, or playback data to be sent to the MSFN while voice, real-time data, and ranging are being sent simultaneously via the transponder. The transmitter VCO receives modulation from the FM mixer or TV output of the PMP. The frequency modulator signal passes through two stages of amplification and then is sent through three multipliers, X2, X3, and X5 respectively. A ferrite circulator is used on the output of the final multiplier to preclude reflected power from feeding back and degrading the signal. The output power is approximately 100 mw. The USBE FM transmitter requires about 8 watts of 3-phase 400-cycle a-c power and 1 watt of 28-vdc power.

TELECOMMUNICATION SYSTEM

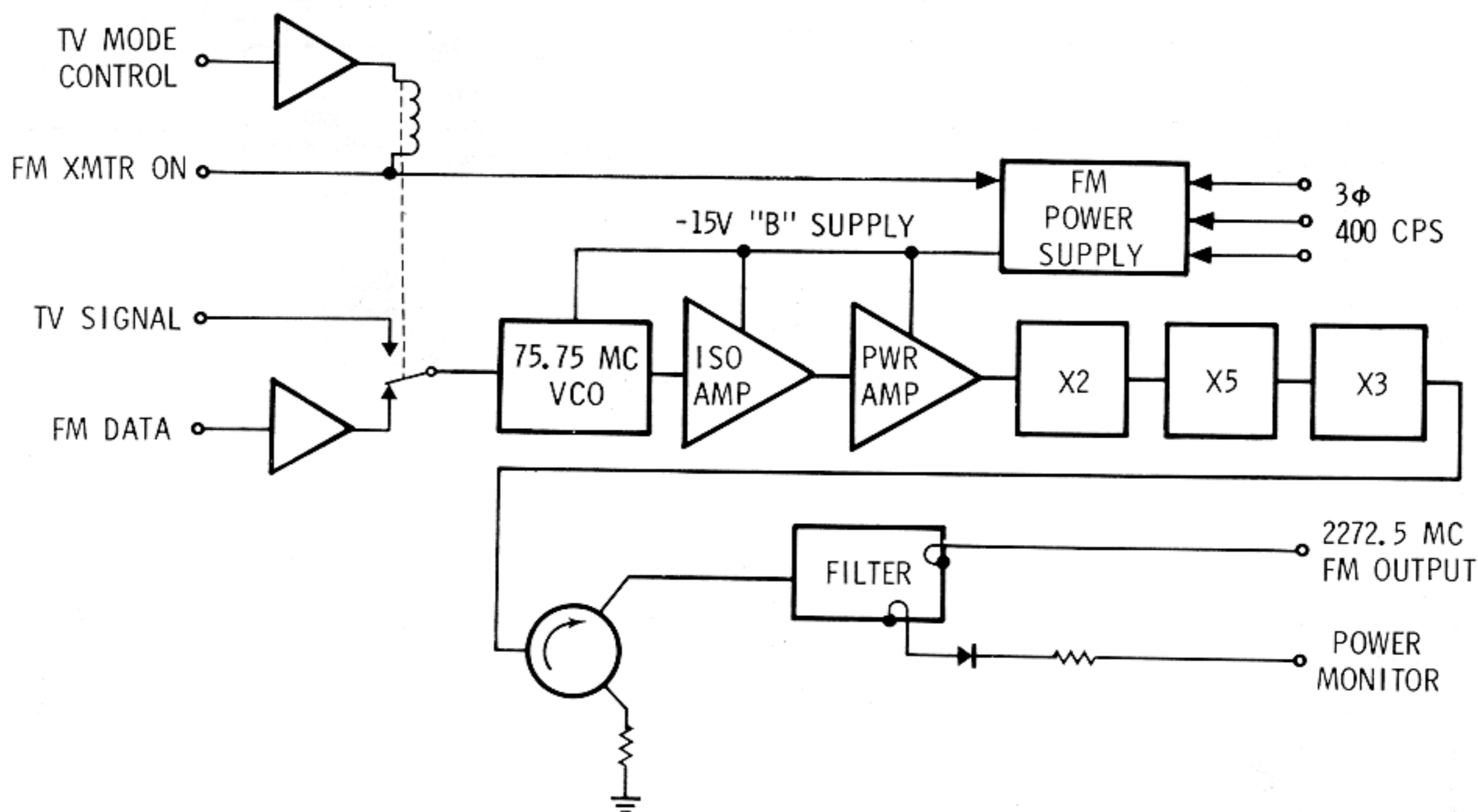

CD-2037A

T/C

Figure 2.8-20. S-Band FM Transmitter

Operational configurations of the USBE are controlled by the S-band switches on MDC-3. Individual functions are described in the Controls and Displays, section 3, while control circuits involved with the USBE are shown in Figure 2.8-21.

2.8.3.4.4 S-Band Power Amplifier Equipment.

The S-band power amplifier (PA) equipment (figure 2.8-22) is used to amplify the RF output from the USBE transmitters when additional signal strength is required for adequate reception of the S-band signal by MSFN. The amplifier equipment consists of a triplexer, two traveling-wave tubes for amplification, power supplies, and the necessary switching relays and control circuitry. The S-band PA is contained in single electronics package located in the lower equipment bay. Each power amplifier

SM2A-03-BLOCK II-(1)
 APOLLO OPERATIONS HANDBOOK

SYSTEMS DATA

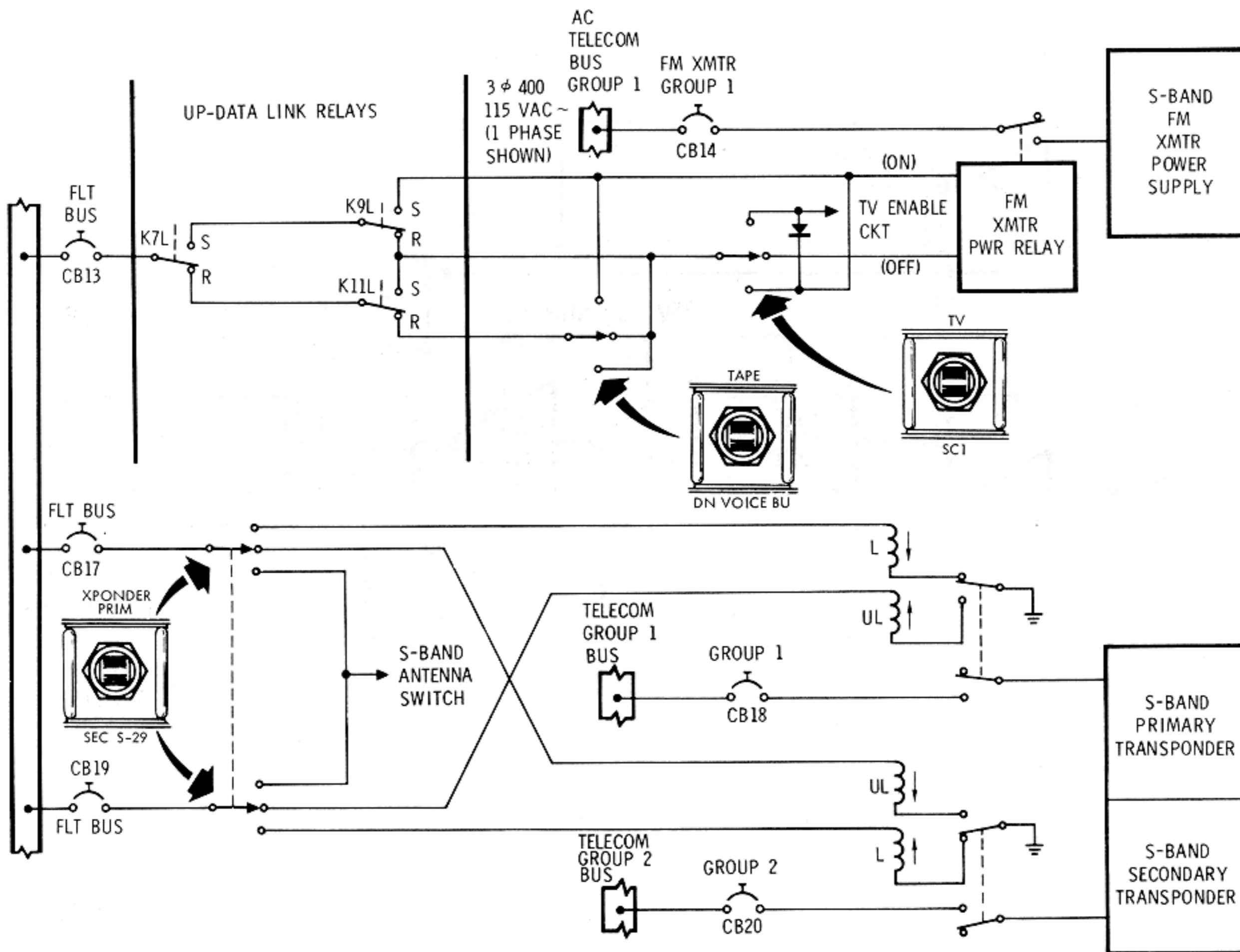

CD-2060D

Figure 2.8-21. Unified S-Band Switching

requires about 15 watts of warm-up, 45 watts at low-power and 90 watts at high-power of 3-phase 400-cycle a-c power and about 2.5 watts of 28-vdc power.

All received and transmitted S-band signals pass through the S-band PA triplexer. The 2106.4-mc S-band carrier, received by the SC, enters the S-band PA triplexer from the S-band antenna equipment. The triplexer passes the signal straight through to the USBE receiver. The 2287.5-mc output signal from the USBE transponder enters the S-band PA where it is either bypassed directly to the triplexer and out to the S-band antenna equipment, or amplified first and then fed to the triplexer. There are two power amplifier modes of operation: low power and high power. The high-power mode is automatically chosen for the power amplifier connected to the FM transmitter.

TELECOMMUNICATION SYSTEM

SYSTEMS DATA

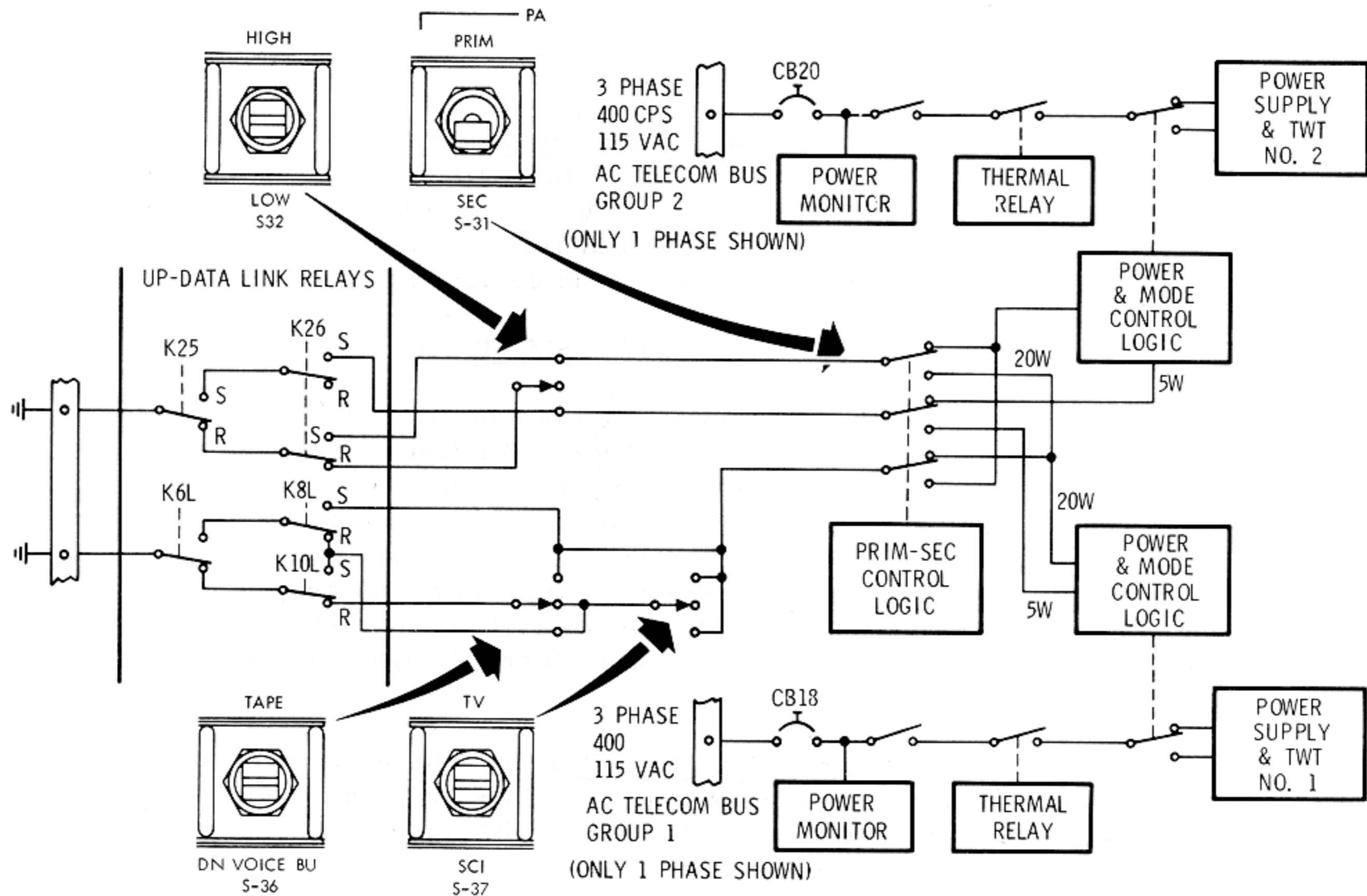

T/C

CD-20583

Figure 2.8-22. S-Band Power Amplifier Control and Power Switching

Power for the power amplifier comes from the telecomm group circuit breakers 1 and 2. Separate 3-phase 115-volt 400-cps power sources are employed to drive each traveling wave tube and its attendant power supply. Figure 2.8-22 shows the controlling circuits involved with power distribution to the power amplifier.

2.8.3.4.5 Premodulation Processor Equipment.

The premodulation processor (PMP) equipment provides the interface connection between the airborne data-gathering equipment and the RF electronics. The PMP accomplishes signal modulation and demodulation, signal mixing, and the proper switching of signals so that the correct intelligence corresponding to a given mode of operation is transmitted.

SYSTEMS DATA

These modes, which are listed in this section, are shown on the S-band operational spectrum (figure 2.8-25). The PMP uses a maximum power of 12.5-watt at 28-volt d-c.

Voice

Command Module Normal S-Band Down Voice. The input voice signal from the audio center equipment is pre-emphasized, clipped, and frequency modulates the 1250-kc voice VCO. The voice subcarrier may be frequency-multiplexed with the PCM/PM 1024-kc subcarrier for PM transmission via the USBE (unified S-band equipment).

Voice Conference Between LM or EVA/CSM/MSFN.

The received VHF/AM LM or EVA voice is amplified and linearly mixed (time-shared) with the real-time CSM voice for frequency modulating the 1250-kc voice VCO. The received S-band up-voice 30-kc subcarrier is demodulated and parallel outputs are provided for input to the audio center equipment and for the navigator's mike input to the navigator's audio center. With the navigator's audio control panel positioned for VHF/AM VOX transmission to EVA or LM, the relay of MSFN voice may be accomplished. The above provisions give a conference capability between LM or EVA, CSM, and MSFN.

Command Module Backup S-Band Down Voice. The input voice signal from the audio center equipment is pre-emphasized and clipped. The voice signal is then routed directly to the USBE, bypassing the voice modulator, for base band phase-modulation (PM) on the S-band carrier transmission to MSFN.

Recorded CSM Intercom/LM Voice. An AGC circuit is provided to process LM voice which is linearly mixed with the input voice signal from the CSM intercom bus. An isolation amplifier is used at the CSM INTERCOM/LM voice output for recording in the DSE (data storage equipment).

MSFN to CSM S-Band Normal Up-Voice. The MSFN up-voice is PM/FM voice via S-band. The received, frequency-modulated 30-kc subcarrier from the USBE is bandpass-filtered and demodulated in the PMP. The output voice signal is low-pass filtered and routed to the audio center equipment input.

MSFN to CM S-Band Backup Up-Voice. The MSFN backup up-voice is PM/FM voice via S-band. The MSFN voice is switched from the 30-kc subcarrier to the 70-kc subcarrier and linearly mixed with the up-data. This bypasses the up-voice detector in the PMP.

SYSTEMS DATA

CSM INTERCOM/LM Voice Playback. The playback-to-record ratio may be either 32:1 or 1:1 dependent upon the CSM PCM recorded bit rate. The input signal from the DSE is limited, filtered, and frequency-multiplexed with the three scientific subcarriers and stored PCM data on the 1024-kc subcarrier for FM transmission via the USBE.

Command Module Television. The CSM television camera input signal is a direct dc-coupled output signal to the USBE for FM base band transmission. An additional isolation amplifier attenuator circuit is provided for ac-coupled output to the spacecraft umbilical.

Real-Time Telemetry.

Command Module PCM Data. The CSM PCM data input signal biphase modulates the 1024-kc subcarrier. The subcarrier is filtered and frequency-multiplexed with the voice 1250-kc subcarrier. The output signal phase-modulates (PM) the carrier for transmission via the USBE.

EVA Biomedical Data Relay Via S-Band. The relay of EVA biomed will be accomplished simultaneously with CSM or EVA voice in the same manner as described in the voice conference mode.

MSFN to CSM S-Band Up-Data. The up-data signal is processed the same as up-voice except the subcarrier center frequency is 70 kc and the output is routed to the up-data link decoder.

Scientific Analog Data. Three real-time scientific analog telemetry inputs frequency-modulate three subcarrier oscillators. The three real-time subcarrier signals are mixed and the composite signal frequency-modulates the S-band carrier for FM transmission via the USBE.

T/C

Recorded Telemetry.

CM PCM Stored Data. The CSM stored PCM TLM data biphase modulates the auxiliary 1024-kc sine wave subcarrier. This subcarrier is frequency-multiplexed with the playback of scientific data and LM/INTERCOM voice for modulation of the S-band FM modulator and transmission to MSFN.

LM Stored Data. The LM stored data is played back at 32:1, linearly attenuated and directly modulated base band on the S-band FM carrier.

Scientific Stored Analog Data. The stored scientific analog data frequency-modulates three subcarrier oscillators (SCO). The SCOs are frequency-multiplexed with the stored PCM/TLM 1024-kc subcarrier and the LM/INTERCOM voice playback signal. The composite signal frequency-modulates the S-band equipment.

SYSTEMS DATA

CM to MSFN Emergency Key. To provide a keyed output for emergency key communications, the 512-kc CTE clock input may be keyed by depressing the XMIT side of the rocker switch located on the astronaut's comm cable. The key closure controls a gated amplifier from which the keyed signal is routed to the USBE. A 400-cps sidetone is also keyed by the PTT. This signal is mixed into the PMP up-voice output circuitry and routed through the audio center to the earphones. The S-BAND-T/R switch on the audio control panel is set to T/R or REC.

Redundancy.

CM Backup S-Band Down Voice. The CM voice input is pre-emphasized, clipped, and routed directly to the S-band for PM transmission, bypassing the PMP voice modulator.

CM Auxiliary PCM Telemetry Subcarrier Modulator. The real-time PCM TLM input may be switched by S54 (AUX position) to the auxiliary biphas modulator with the output being switched to the PMP PM MIXER output for S-band PM transmission and to the FM mixer output for S-band FM transmission.

MSFN to CM S-Band Backup Up-Voice. The MSFN voice is placed on the 70-kc up-data subcarrier. This enables the use of the 70-kc subcarrier for time-shared voice and data.

Auxiliary Power Supply. The PMP has redundant switchable regulators to provide power to all PMP circuitry. When switch S54 is in the AUX position, the auxiliary +18-volt d-c regulator is in use. Also the auxiliary 1.024-mc biphas modulator which normally handles stored CM PCM data is switched to handle real-time CM PCM data.

PMP Operational Modes and Output Levels. Output signals are provided in combinations and levels as described in the following. Control panel switches, used to achieve the various modes are illustrated in the block diagram (figure 2.8-23).

Primary Power Control. When S54 switch is in the NORMAL position, power is supplied to all PMP circuitry from the normal +18-volt regulator. When switch S54 is in AUX position, auxiliary +18-volt regulator is used. Also the auxiliary 1.024-mc biphas modulator which normally handles stored CM/PCM data is switched to handle real-time CM/PCM data.

Scientific Data Output to DSE. The three R/T scientific analog data signals are supplied to the DSE through the PMP except when switch S37 is in the SCI position.

SYSTEMS DATA

BI-PHASE MODULATOR:

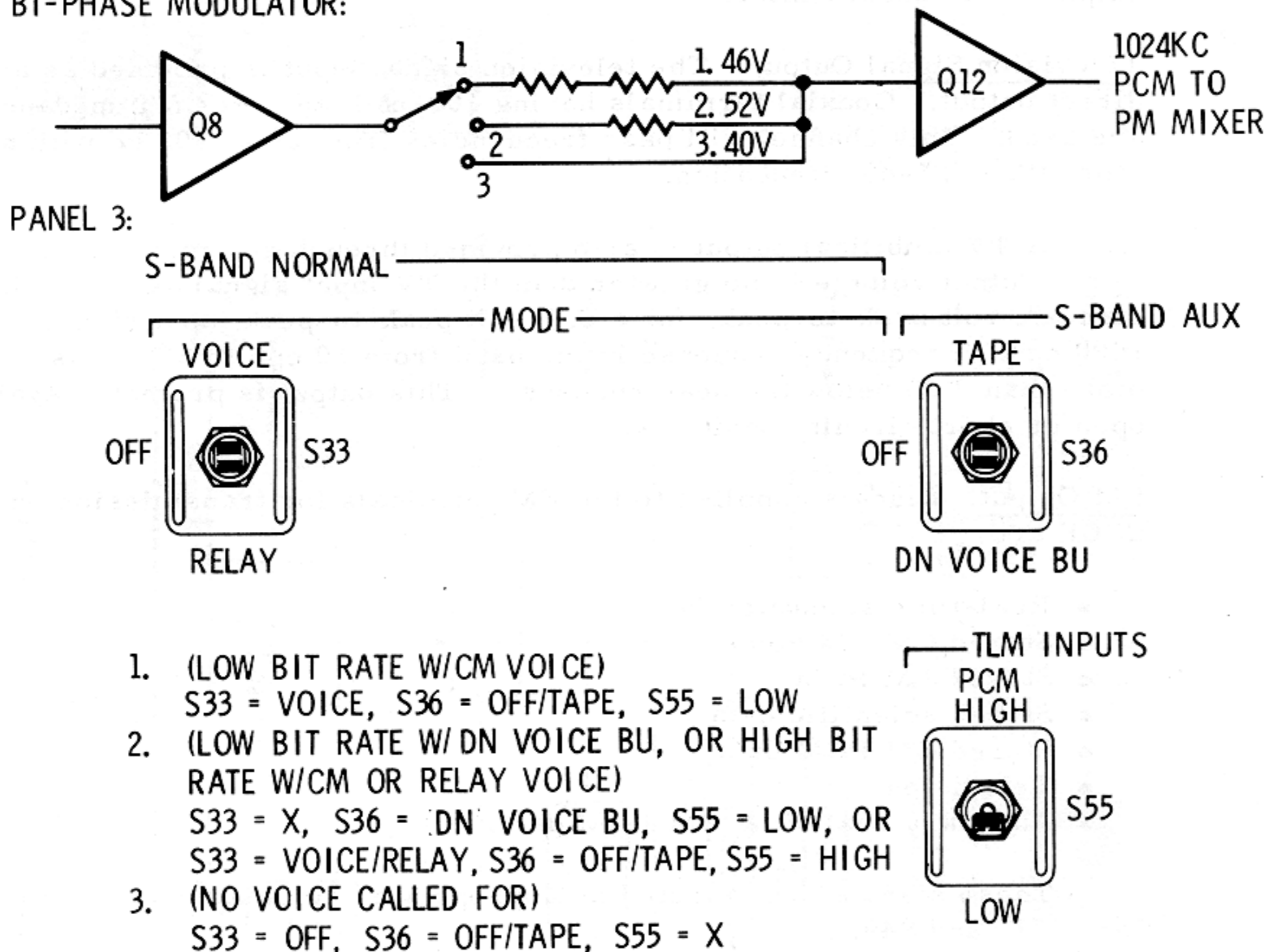

CD-2054D

T/C

Figure 2.8-23. PMP Data Modulation Levels

When S37 is in the SCI position, the three R/T scientific analog data signals are applied directly to the FM mixer in the PMP for transmission via the S-band FM transmitter.

Intercom/LM Voice Output to DSE. The intercom and LM voice output is supplied for DSE recording at all times power is applied to the PMP.

Up-Voice and Up-Data Output. When switch S38 is in the DATA position, the up-voice signal from the 30-kc demodulator is supplied as an output to the audio center. The 70-kc demodulator supplies an up-data output to the up-data link decoder.

SM2A-03-BLOCK II-(1)
APOLLO OPERATIONS HANDBOOK

SYSTEMS DATA

When switch S38 is placed in the BU VOICE position, the 70-kc demodulator output is switched to the up-voice output terminals, as an output to the audio center.

Television Signal Output. The television signal input is provided as a direct output. Coaxial terminals having 100-ohm ± 5 percent impedance are used. This channel will pass frequencies from dc to 500 kc with no more than 0.5-db attenuation.

A TV umbilical output is also provided through an isolation amplifier. Output voltage is no greater than the TV input signal and is no less than one volt peak-to-peak, for a 1.9-volt peak-to-peak input signal at 1000 cps. Frequency response in the band from 10 cps to 500 kc is no more than 3 db below the peak response. This output is protected against open or short circuit conditions.

FM Output. Signals supplied to the FM terminals for transmission on USBE are:

- Real-time scientific data
- Stored CM LM voice
- Stored LM PCM
- Stored scientific data
- Stored CM PCM data
- Television
- Auxiliary real-time CM PCM data.

These signals are selected by appropriate combinations of switches S36, S37, and S49.

PM Output. Subcarriers are selected by suitable configurations of switches. Subcarriers selected for phase modulation of the USBE are:

- 1.024-mc biphase modulated by real-time CM PCM data
- 1.25-mc VCO frequency modulated by:
 - CM voice, or
 - CM voice and LM/EVA voice and biomedical data
- 512-kc emergency key signal.

These signals are selected by appropriate combinations of switches S33, S34, S36, and S44. Switch positions and the output level of each sub-carrier are shown on figure 2.8-23.

The overall functions of the PMP are summarized in figure 2.8-24.

SM2A-03-BLOCK II-(1)
 APOLLO OPERATIONS HANDBOOK

SYSTEMS DATA

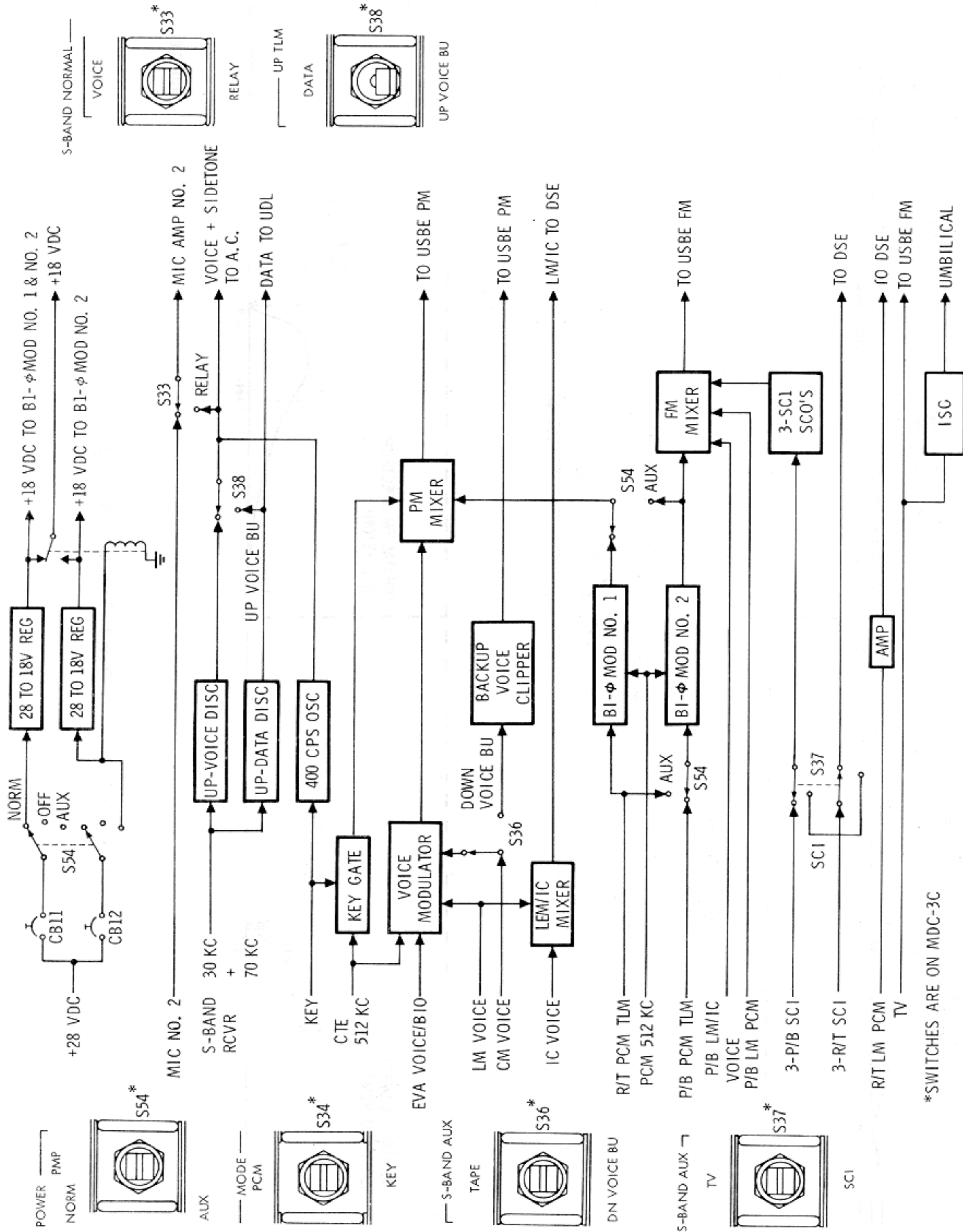

CD-2027H

Figure 2.8-24. PMP Block Diagram

*SWITCHES ARE ON MDC-3C

T/C

TELECOMMUNICATION SYSTEM

SYSTEMS DATA

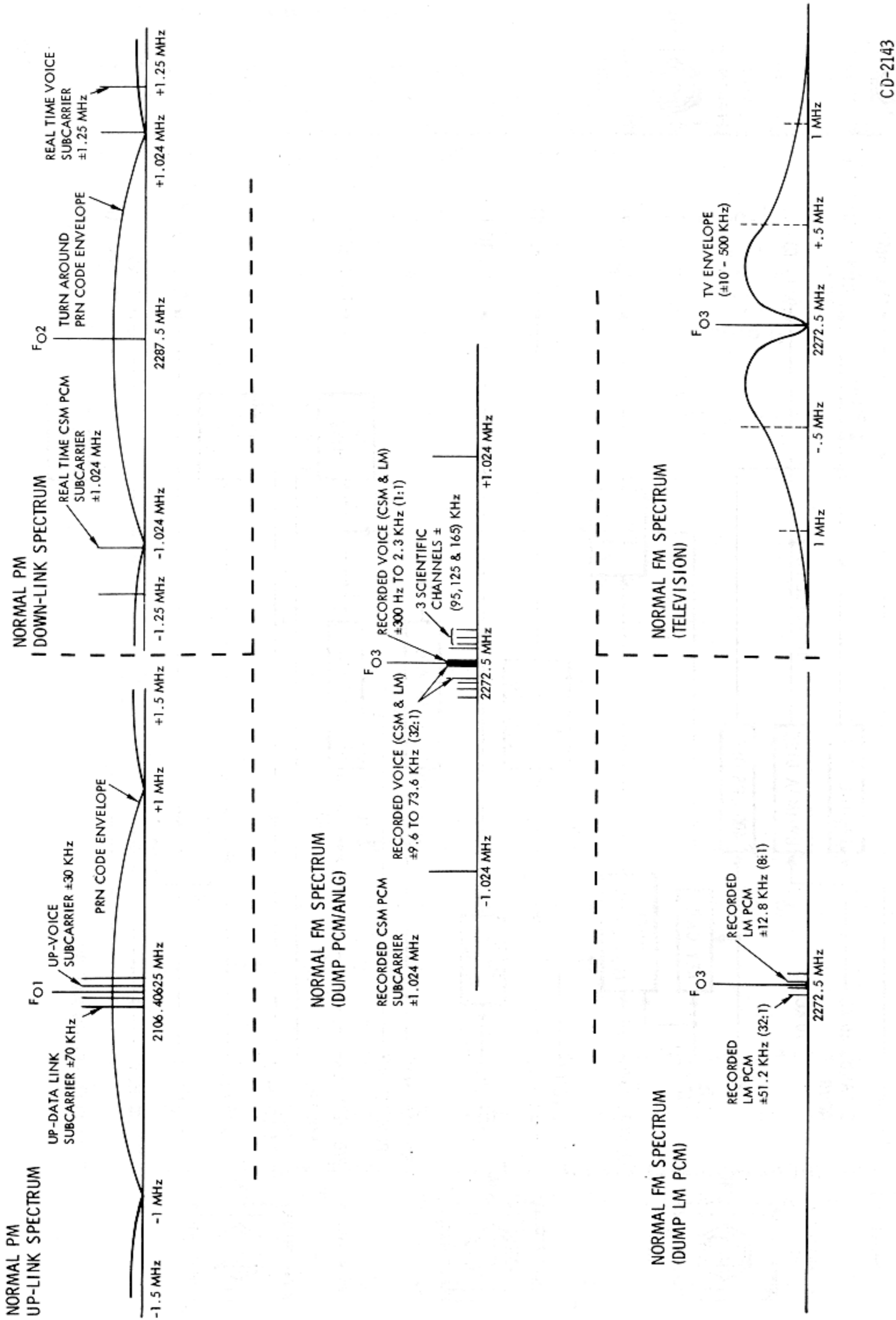
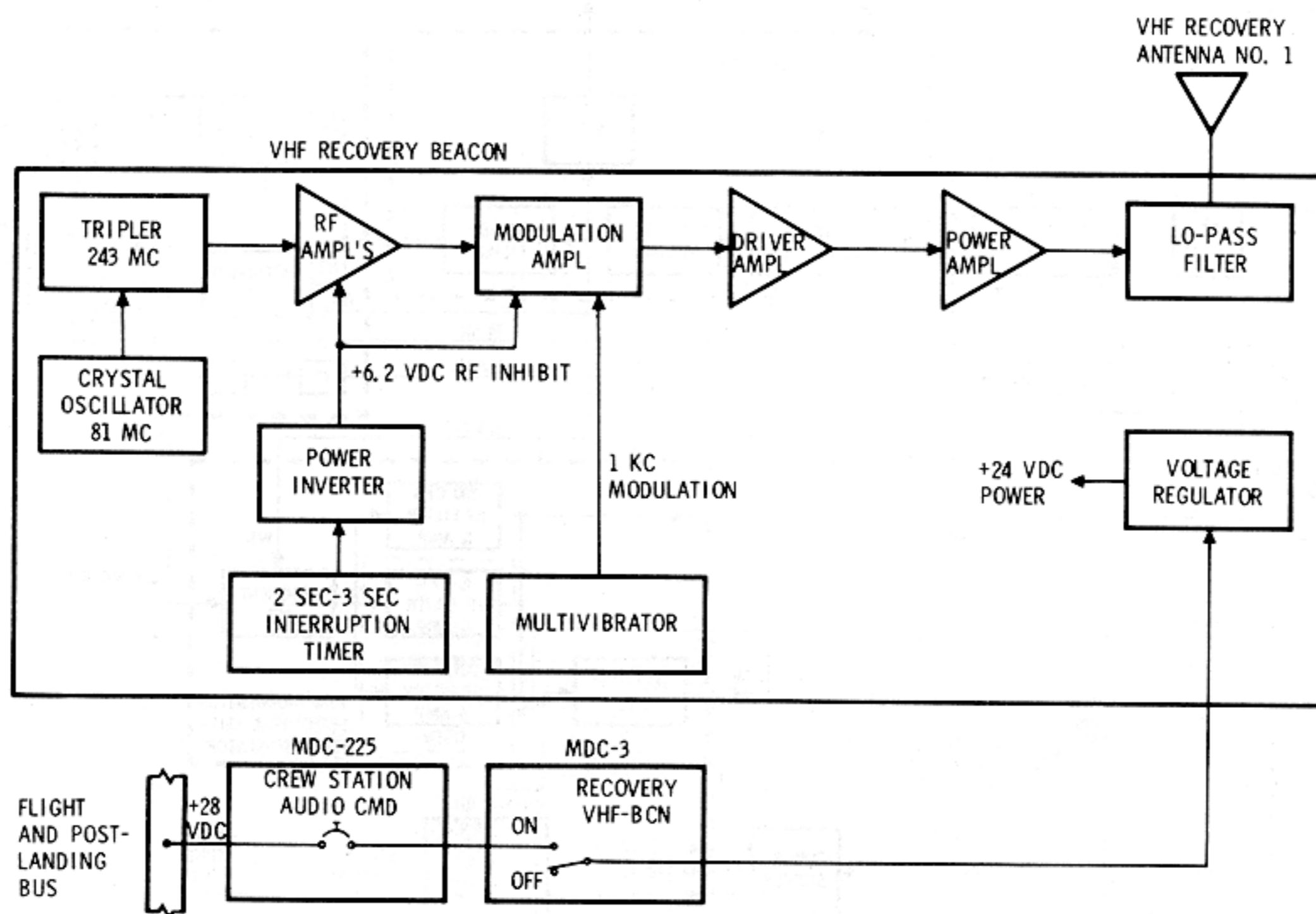

Figure 2.8-25. S-Band Operational Spectrums

CD-2143

SYSTEMS DATA



CD-2062C

T/C

Figure 2.8-26. VHF Recovery Beacon Equipment

2.8.3.4.6 VHF Recovery Beacon Equipment.

The VHF recovery beacon equipment (figure 2.8-26) provides line-of-sight direction-finding capabilities to aid in locating the SC during the recovery phase of the mission. The 3-watt beacon signal emitted is an interrupted 243-mc carrier, modulated by a 1000-cps square wave. The signal is transmitted for 2 seconds, then interrupted for 3 seconds.

Manual control of the equipment is provided by the RECOVERY—VHF-BCN, two-position ON/OFF switch on MDC-3. The beacon requires a maximum of 10-watt of 28-vdc power.

SYSTEMS DATA

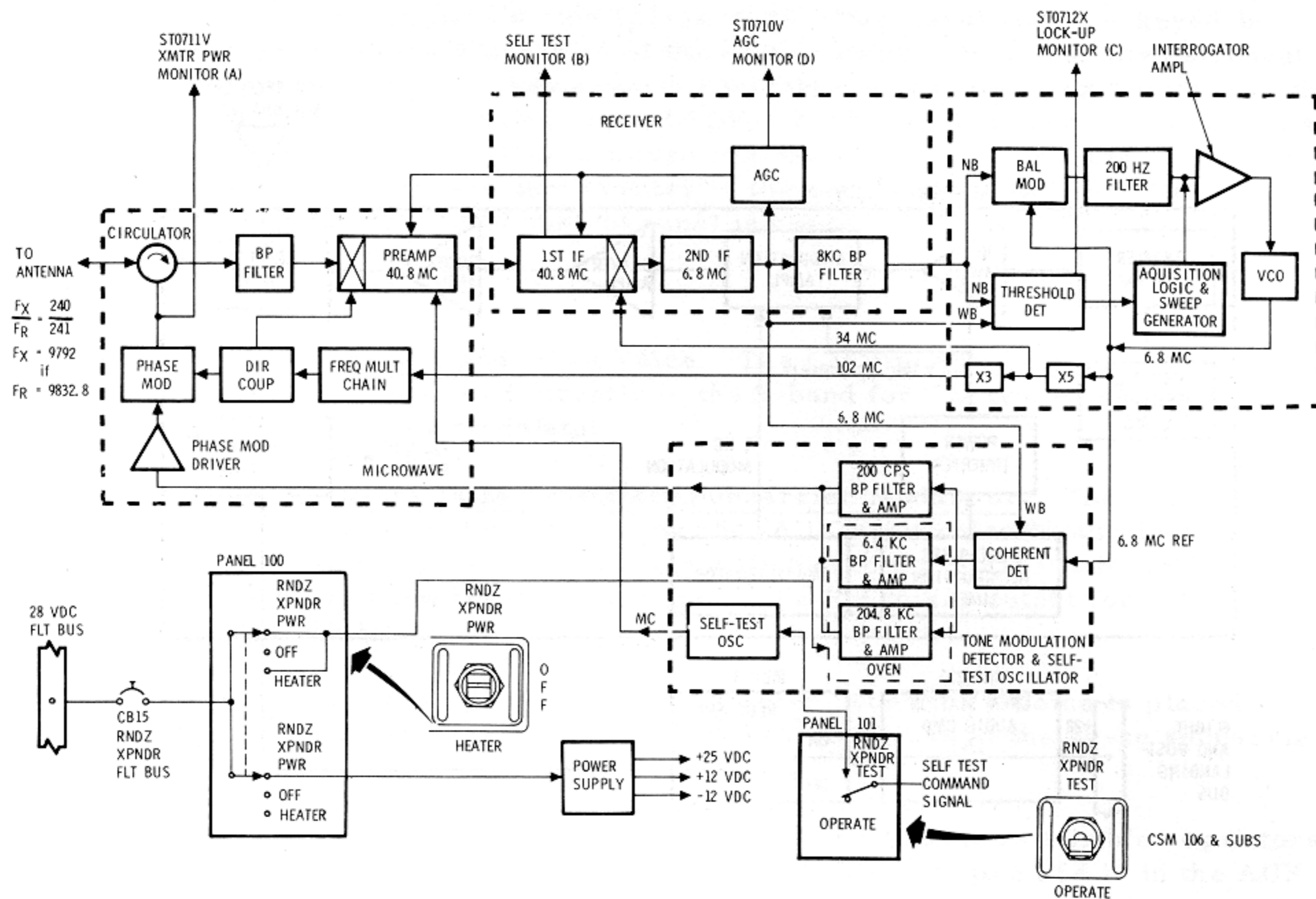

CD-2051D

Figure 2.8-27. RRT Block Diagram

The output of the VHF recovery beacon equipment is fed to VHF recovery antenna No. 1, which is deployed automatically when the main chutes are deployed.

2.8.3.4.7 Rendezvous Radar Transponder.

The transponder (figure 2.8-27) is located in the command and service module (CSM) and performs the function of receiving the LM rendezvous radar (RR) X-band CW signal, and retransmitting (back to the LM) a phase-coherent signal.

The 240-milliwatt return signal is offset in fundamental carrier frequency from the received signals and contains the same modulation components phase-related with respect to the received signal.

SYSTEMS DATA

The transponder is a part of the LM radar subsystem which consists of a rendezvous radar in the LM, the transponder in the CSM, and a landing radar mounted in the descent stage of the LM. The landing radar and the descent stage are left on the lunar surface when the lunar exploration is completed.

During the descent to the lunar surface, the LM and CSM maintain continuous radar contact through the rendezvous radar-transponder link. During the latter part of the descent phase, the landing radar measures the altitude and velocity of the LM with respect to the lunar surface.

At the end of the lunar stay, the rendezvous radar in the LM is used to track the transponder in the orbiting CSM to obtain orbital parameters, which are used to calculate the launching of the LM into a rendezvous trajectory.

In the rendezvous phase, the LM and CSM again maintain radar contact to obtain information needed for midcourse correction, rendezvous, and docking operations. By accepting the weak rendezvous radar transmitted signal, as discussed in preceding paragraphs, and by retransmitting (back to the LM) the phase-coherent return signal, the range capabilities are greatly increased.

Performance Characteristic.

Range. Operates with the rendezvous radar (RR) in a closed loop tracking system at LOS range between 50 feet and 400 NM.

Range Accuracy. The transponder will retransmit each of the range tones received from the rendezvous radar at the following maximum phase shifts:

Tone Frequency	Max. Deg. Phase Shift
200 cps	±0.69°
6.4 kcs	±1.0°
204.8 kcs	±3°

Range Rate Accuracy. 1/4 percent or 1 foot per second (whichever is greater) based on an LGC sampling period of 100 milliseconds.

Angular Coverage. Angular coverage over a solid angle of 160° by 105°.

Acquisition. Acquires the rendezvous radar with a detection probability of 98 percent in a period of 1.3 seconds with a signal equal to or greater than -123 dbm at the transponder antenna.

T/C

TELECOMMUNICATION SYSTEM

SYSTEMS DATA

Mode Activation.

Signal Search Mode. The transponder will be in the signal search mode at all times that the transponder is in an ON condition and no signal is being received from the rendezvous radar.

Transponder Mode. The transponder will be in its transponder mode at all times that a signal is being received from the rendezvous radar. Signals equal to or greater than -123 dbm which fall within the transponder frequency range are automatically detected and acquired by the transponder.

Self-Test Mode. The transponder will be in the self-test mode when the self-test enable signal is applied to the transponder assembly.

Standby Mode. The transponder will be in standby mode when the heater position is selected for the 24 minutes it takes to warm the filters to $160^{\circ} \pm 1^{\circ} \text{F}$.

Antenna Characteristics.

Coverage. Gain is maintained over a solid angle of $160^{\circ} \times 105^{\circ}$.

Polarization. Linear with cross-polarized components 20 db down from the main component.

Transmit Energy Characteristics.

Power. Greater than 240 milliwatts.

Frequencies. Signal search, 9792.0 mc ± 25 kcs and swept ± 104 kc minimum.

Transponder mode equal to the received frequency times 240/241.

Received Signal Characteristics.

Frequency. 9832.8 mc ± 30 kc offset by a doppler frequency within the range of ± 49 kc with maximum rate of change of 500 cps².

Signal Level. At antenna terminals, -123 dbm to -18 dbm.

Self Test.

Self-Test Oscillator. Provides 40.8 mc for receiver testing and is coupled into the receiver preamplifier.

SM2A-03-BLOCK II-(1)
APOLLO OPERATIONS HANDBOOK

SYSTEMS DATA

Self-Test Enable. From control/display +12 vdc ± 10 percent and current of 20 ma ± 10 percent.

Self-Test Enable Supply. From transponder to the control/display assembly self-test switch +25 volts ± 10 percent.

Receiver Self-Test Output. From transponder to the control/display monitor meter, panel 101.

Monitor outputs to the control/display panel:

AGC monitor	0 to 4.5 volts
Frequency lockup search	0 \pm 0.4 volts dc
Transponder mode	4.5 volts dc ± 10 percent

Transmitter Power. 2.5 \pm 0.4 volts dc for specified minimum power (5 volts dc maximum).

Electrical Requirements.

Operating voltage	Normal 25 to 31.5 volts
Emergency periods not exceeding 5 seconds	+20 to +25 volts dc +31.5 to +32 volts dc
Transients limits not exceeding 5 minutes	+50 volts for 10 usec at 10 pps repetition rate. -100 volts for 10 usec at 10 pps repetition rate.

Power Requirements.

Maximum input power excluding heater	60 watts at +28 vdc
--------------------------------------	---------------------

2.8.3.5 Antenna Equipment Group.

The antenna equipment group contains all the SC antennas and ancillary equipment used in the T/C system. For the antenna locations, see figure 2.8-28.

2.8.3.5.1 VHF Omnantenna Equipment.

The VHF omnantennas and ancillary equipment consist of two VHF scimitar antennas, a VHF triplexer, a VHF antenna switch, and the necessary signal and control circuits. The function of this equipment is to provide capabilities for radiation and pickup of RF signals in the VHF

TELECOMMUNICATION SYSTEM

SYSTEMS DATA

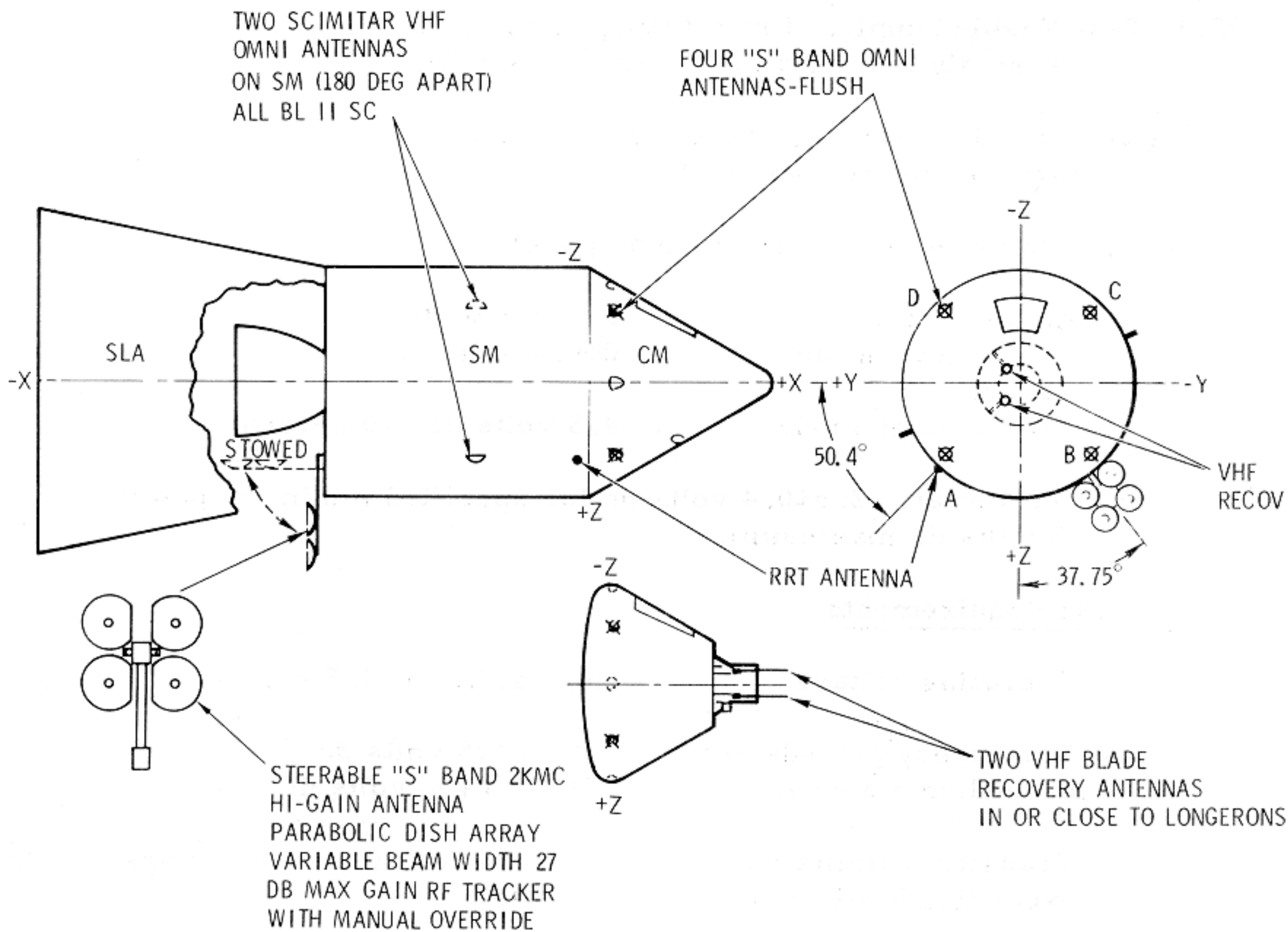

CD-2003H

Figure 2.8-28. Antenna Locations

spectrum. The VHF/AM transceivers, which work through this equipment, operate at 296.8 mc and 259.7 mc. Provisions are also made for the checkout of the PLSS communication equipment through this equipment.

The VHF triplexer is a passive, three-channel filtering device which enables three items of VHF transmitting and receiving equipment to utilize one VHF antenna simultaneously. The three-channel filters are composed of two tuned cavities each, which function as bandpass filters. No power is required by the device and there are no external controls.

The VHF scimitar antennas, shown in figure 2.8-29, are omni-antennas with approximately hemispherical radiation patterns. Because of its characteristic shape, this type of VHF antenna is called a scimitar.

TELECOMMUNICATION SYSTEM

SYSTEMS DATA

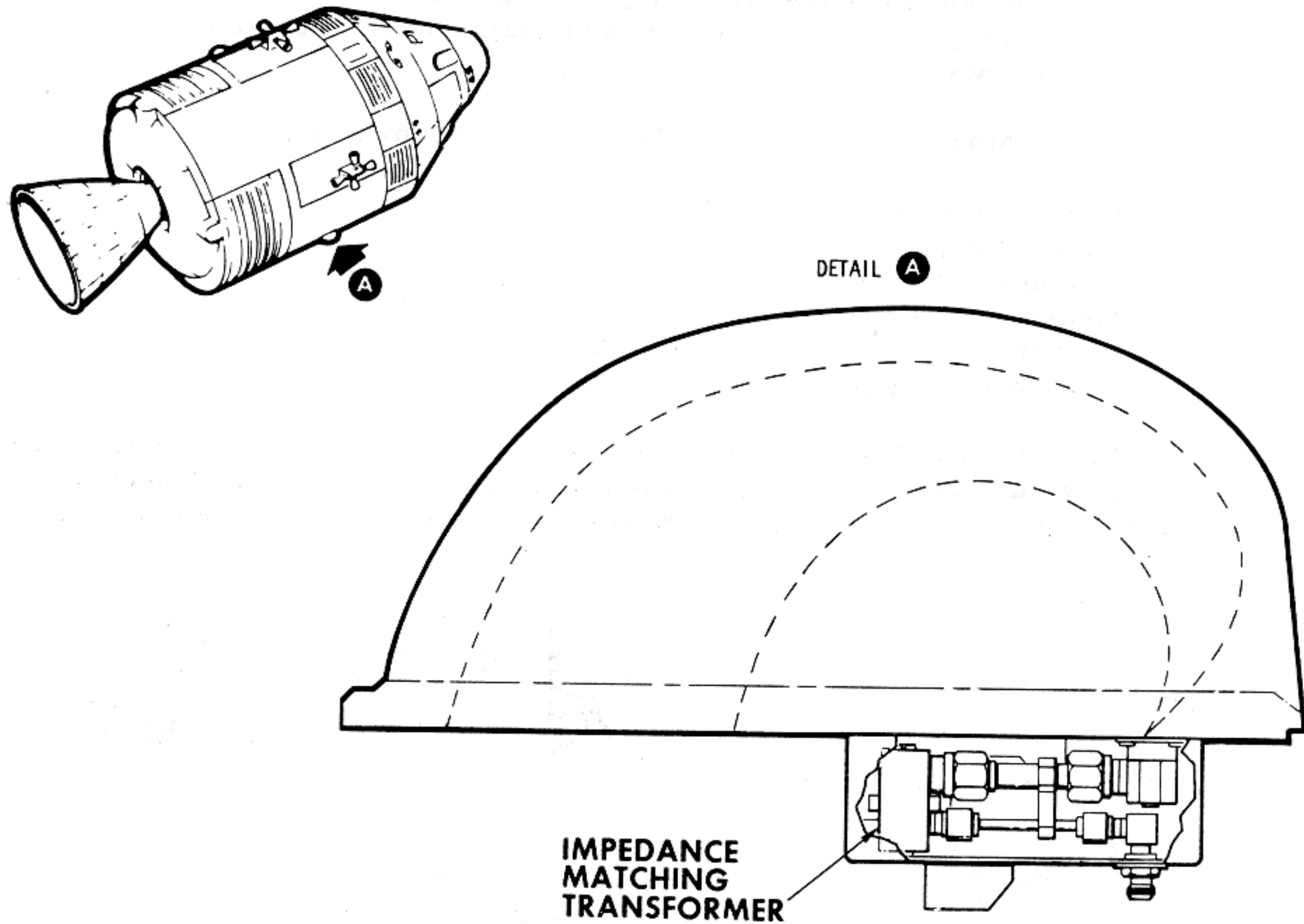

CD-2004A

T/C

Figure 2.8-29. Scimitar Antenna

These two VHF antennas are located on opposite sides of the service module. One is located near the +Y axis and is called the right VHF antenna; the other is located near the -Y axis and is called the left VHF antenna. Because of their approximate hemispherical radiation patterns, full omnidirectional capabilities can be obtained only by switching from one antenna to the other. This is accomplished with the VHF ANTENNA remote control switch on MDC-3 for VHF communications.

2.8.3.5.2 S-Band High-Gain Antenna.

The high-gain antenna is provided for use with the unified S-band equipment to provide sufficient gain for two-way communications at lunar distances. To accomplish this, the antenna can be oriented manually or automatically toward the MSFN stations for maximum operational efficiency.

TELECOMMUNICATION SYSTEM

SM2A-03-BLOCK II-(1)
 APOLLO OPERATIONS HANDBOOK

SYSTEMS DATA

The antenna also has three modes of operation for transmission and two for reception. The nominal gain and beam widths of these modes are listed as follows:

Mode	Gain	Beam Width
Wide-Transmit	9.2 db	40°
Wide - Receive	3.8 db	40°
Medium - Transmit	20.7 db	11.3°
Medium - Receive	22.8 db	4.5°
Narrow - Transmit	26.7 db	3.9°
Narrow - Receive	23.3 db	4.5°

Figure 2.8-30 shows the antenna in both the deployed and nondeployed state. Actual deployment takes place during transposition and docking phase of the mission when the SLA panels are opened. After deployment,

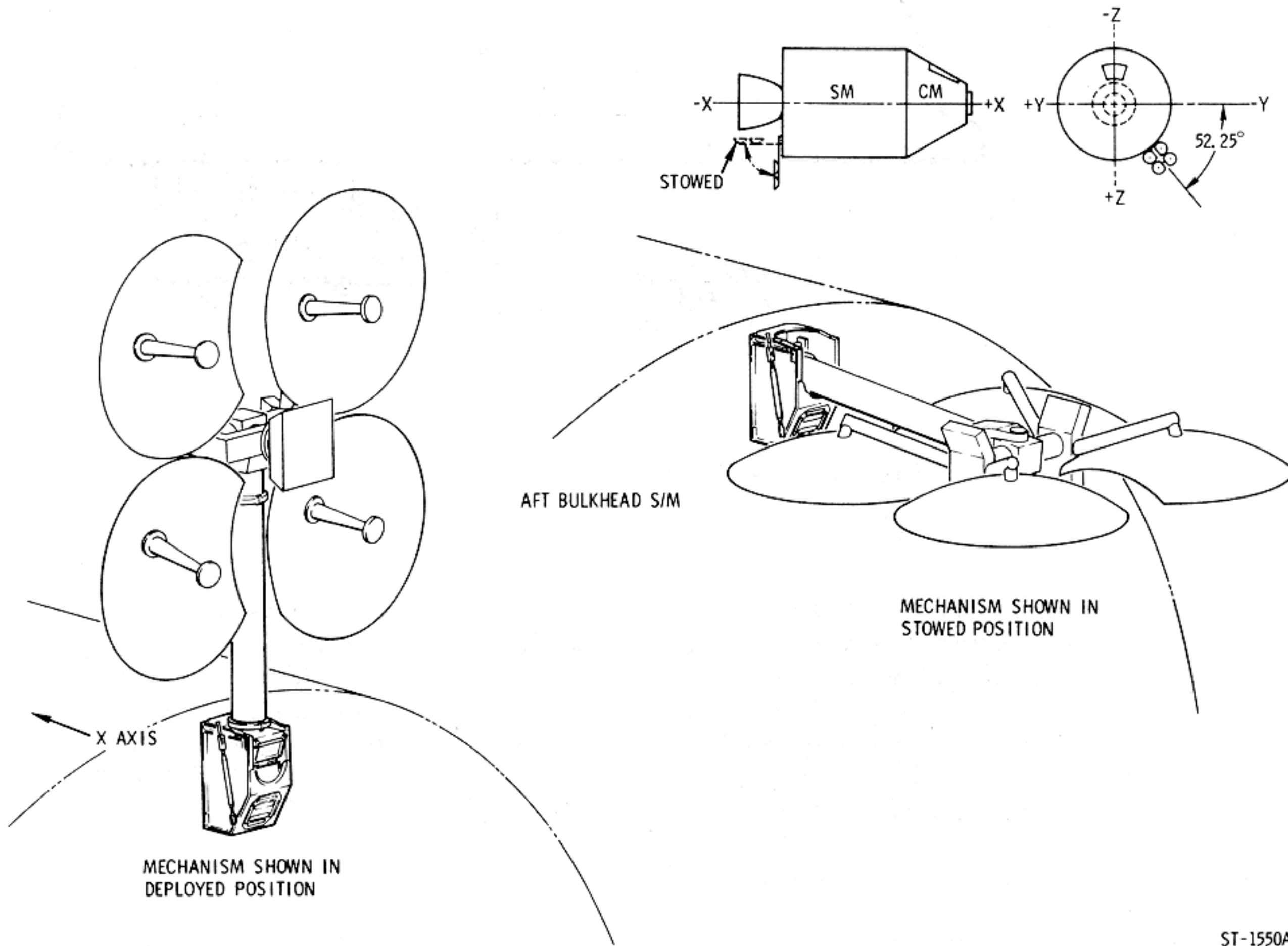

ST-1550A

Figure 2.8-30. High Gain Antenna

SYSTEMS DATA

the positioning circuitry is enabled. Manual controls, position readouts, and a signal strength meter are provided on MDC-2 to allow normal positioning of the antenna for initial signal acquisition. After acquisition, the antenna is capable of automatically tracking the RF signal within the travel limits of its gimbaling system. The propagation and reception mode is selectable on the same panel.

The antenna itself is made up of a four-parabolic dish array whose attendant feed horns are offset 10 degrees for the desired propagation pattern and a cluster of four feed horns enclosed in the center enclosure. In the wide mode, the center feed horns are used for transmission and reception of signals. In the medium mode, one of the parabolic dish-reflector antennas is used for transmission and all four of the dish antennas are used for reception of S-band signals. The narrow mode employs the four parabolic dish antennas for transmission and reception of S-band signals.

2.8.3.5.3 S-Band Omnantennas.

The function of the four S-band omnantennas is to transmit and receive all S-band signals during the near-earth operational phase, with a backup capability to support the high-gain S-band antenna in the lunar sequence. Locations are shown in figure 2.8-28 at $X_c = 20.766$ and 45 degrees off the +Z, -Y, -Z and +Y axis.

The antennas are flush-mounted, right-hand polarized helical, and in a loaded cavity. They are rated at 15 watts cw at 2100 to 2300 mc.

2.8.3.5.4 VHF Recovery Antenna Equipment.

There are two VHF recovery antennas, No. 1 and No. 2, stowed in the forward compartment of the SC. Each antenna consists of a quarter-wave stub, 11 inches long, and a ground plane. They are automatically deployed 8 seconds after main parachute deployment, during the descent phase of the mission. (See figures 2.8-31 and 2.8-32.)

VHF recovery antenna No. 1 is connected to the VHF recovery beacon equipment. VHF recovery antenna No. 2 is to be used with the VHF/AM transmitter-receiver equipment and is connected to the VHF antenna switch with a coaxial cable. An access hatch is provided to allow either of the VHF recovery antennas to be used with the GFE survival transceiver. This requires that the coaxial cable from one of the antennas be manually disconnected at the triplexer and reconnected to the survival transceiver.

TELECOMMUNICATION SYSTEM

SYSTEMS DATA

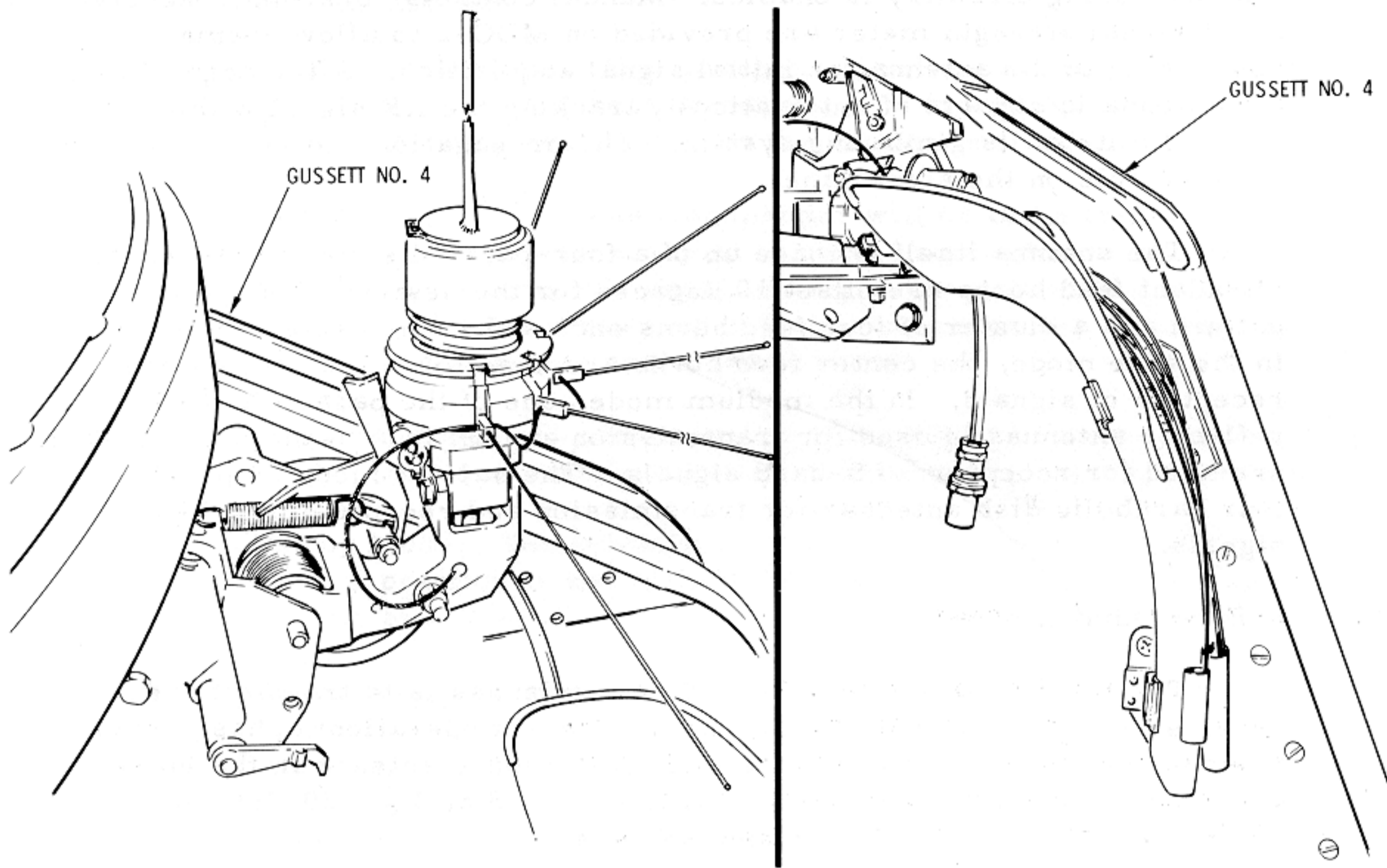

CD2117A

Figure 2.8-31. VHF Recovery Antenna No. 1

2.8.3.6 Electrical Power Distribution.

Electrical power distribution for the intercommunication, data, instrumentation, RF and antenna equipment is summarized on figure 2.8-33. In most cases, the power circuit for each piece of equipment was covered in the respective functional description. The majority of the circuit breakers for the telecommunication system are located on MDC-225.

2.8.4 OPERATIONAL LIMITATIONS AND RESTRICTIONS.

2.8.4.1 VHF-AM.

- a. Simultaneous selection of DUPLEX A and B gives the same operation as selection of SIMPLEX A and B.
- b. Only LM PCM telemetering data can be received only on RCV B DATA.

TELECOMMUNICATION SYSTEM

SYSTEMS DATA

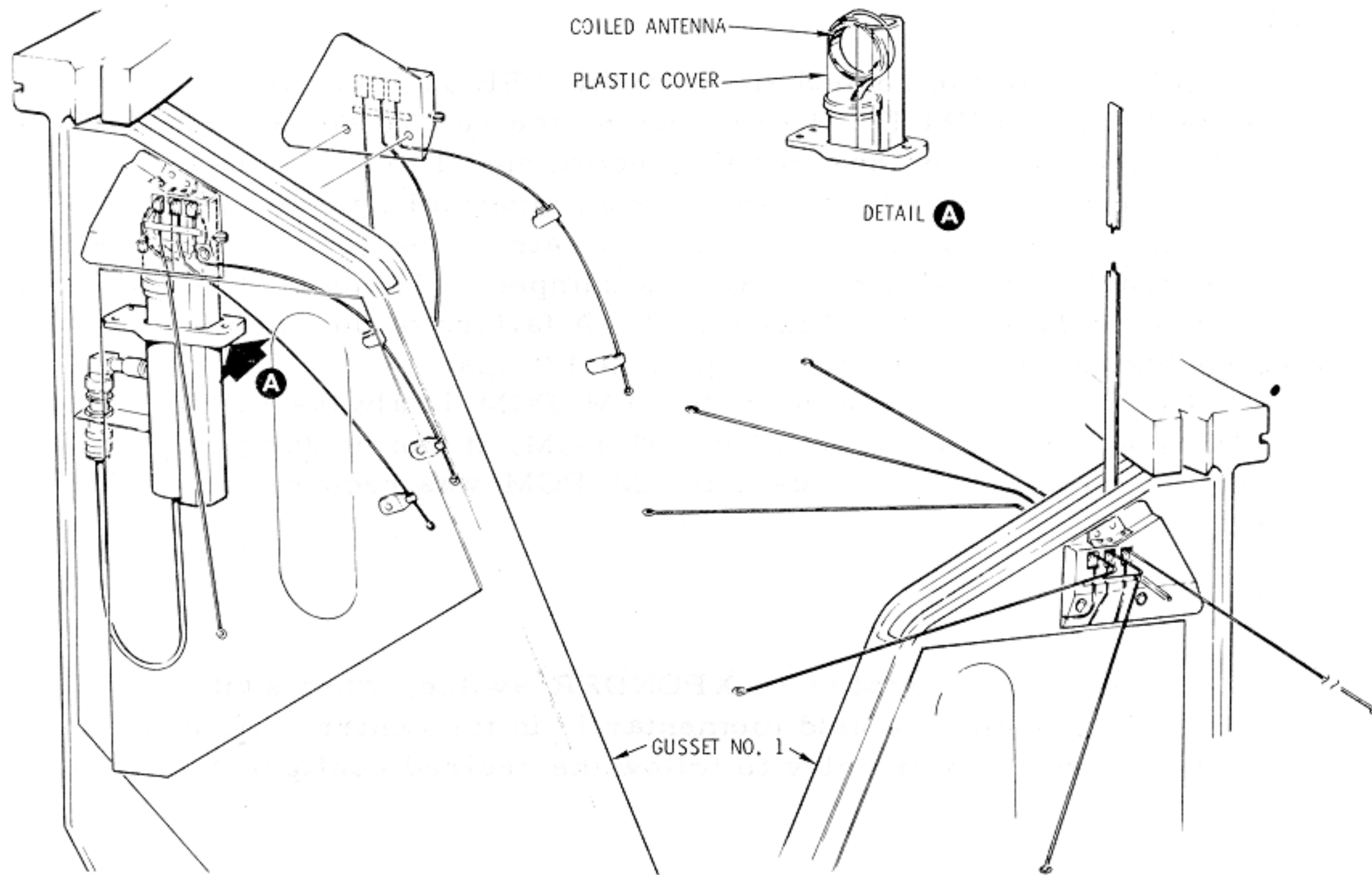

CD2119

Figure 2.8-32. VHF Recovery Antenna No. 2

2.8.4.2 PMP.

- a. When UP TLM/VOICE BU is chosen, the output of the data discriminator is sent to both the audio center and the up-data link equipment.
- b. Low-bit rate PCM data can be transmitted with down VOICE BU. If only VOICE transmission is desired, the PCM switch must be at OFF and the TLM INPUT PCM switch must be at HIGH for the best circuit margins.
- c. Selection of the AUX PMP power supply precludes the transmission of recorded data from the data storage equipment. Real-time PCM is available for transmission over both the S-band transponder and FM transmitter in this mode.
- d. To transmit real-time PCM over the FM transmitter, S-BAND AUX TAPE and PMP AUX POWER should be selected.

T/C

SM2A-03-BLOCK II-(1)
APOLLO OPERATIONS HANDBOOK

SYSTEMS DATA

2.8.4.3 DSE.

a. Selection of the record speed in the DSE is made by the PCM HIGH-LOW switch. If PCM HIGH is selected, the record speed will be 15 ips. A PCM LOW selection changes the record speed to 3-3/4 ips.

b. Selection of the DUMP speed is automatically made by the DSE electronics through monitoring of the bit rate on the recorded CM PCM CLOCK track. High-bit rate PCM is dumped at 15 ips (1:1) while low-bit rate PCM is dumped at 120 ips (32:1). A failure of the speed select electronics causes automatic dumping at 120 ips.

c. The DUMP speed of recorded LM PCM is always 120 ips. If the LM PCM was recorded with LBR CM PCM, it can be dumped at a 32:1 ratio. An 8:1 dump ratio is used if LM PCM was recorded with HBR CM PCM.

2.8.4.4 USBE.

The S-BAND NORMAL - XPONDER switch, when switched between PRI and SEC, should be held momentarily in the center, off, position to allow the internal power relay to follow the desired configuration change.

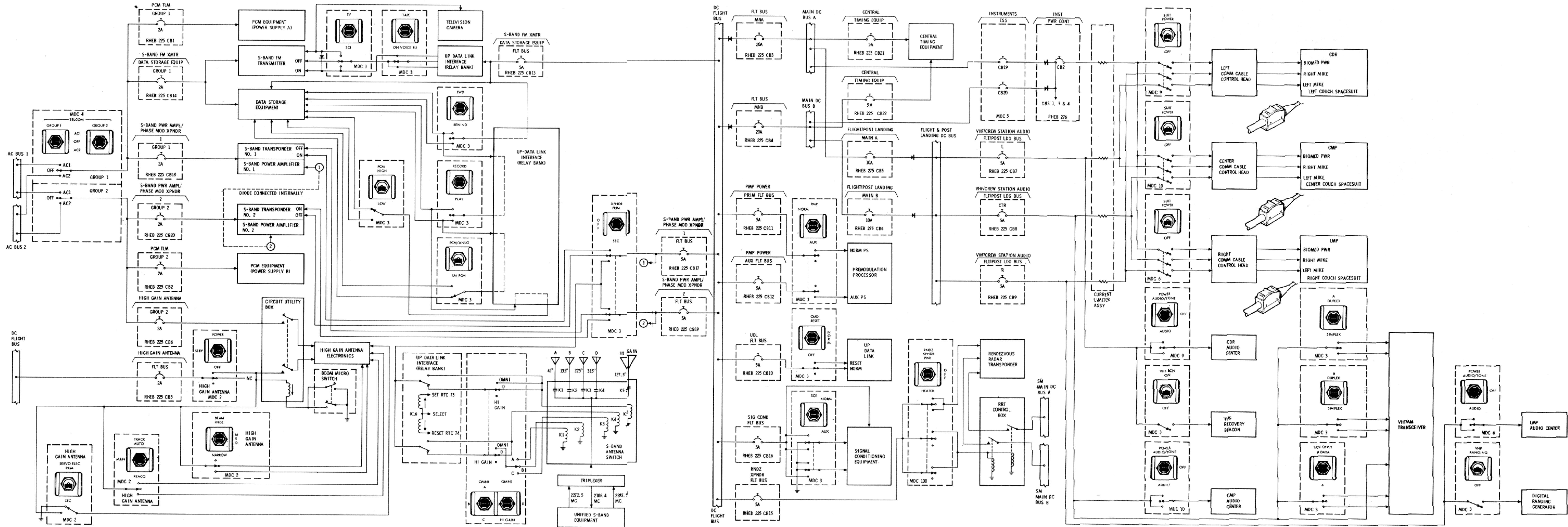

Figure 2.8-33. Telecommunications Power Distribution

TELECOMMUNICATION SYSTEM